

brother

LH4-B815A

高速本縫ボタン穴かがりミシン

HIGH SPEED BUTTONHOLE SEWING MACHINE

KNOPFLOCH-SCHNELLNÄHMASCHINE

MACHINE A COUDRE DE BOUTONNIERES A GRANDE VITESSE

MAQUINA DE COSER OJALES DE ALTA VELOCIDAD

パーツブック

PARTS BOOK

TEILEKATALOG

LIVRE DES PIECES

LIBRO DE REFERENCIA DE PIEZAS

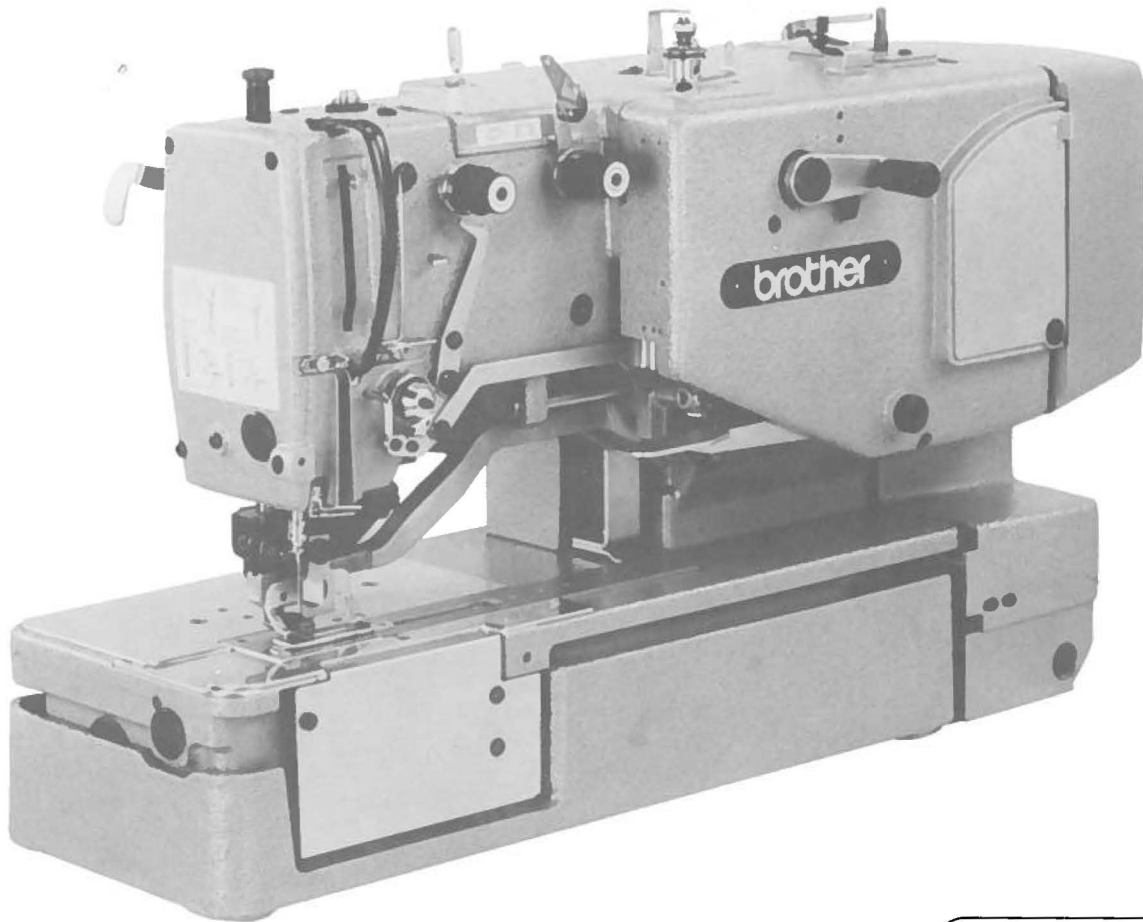

P815401

パーツブックご利用に際して

1. この本は、この本の表紙（正誤表の挿入されている場合は正誤表）に記載されているものと同じプレートが取り付けられているミシンのためのものです。
2. この本は1990年1月のデータに基づいて作成されたものです。
3. 部品は予告なしに設計変更される場合があります。
4. 部品コード欄が*となっている場合は、仕様別部品一覧表（55ページ）でお調べ下さい。

目 次

A. 主体関係.....	2	Q. 下軸関係.....	32
B. 針棒関係.....	6	R. カマ関係.....	34
C. 上軸関係.....	8	S. 給油潤滑関係.....	36
D. 針振関係.....	10	T. 糸通シ関係.....	40
E. 停止関係.....	14	U. 糸巻装置.....	44
F. 減速関係.....	16	V. 上糸切り関係.....	46
G. ベルト寄せ関係.....	16	W. 下糸切り関係.....	48
H. 非常停止関係.....	18	Y. 特別注文部品.....	50
J. テンションプーリ関係.....	18	Z. 付属品関係.....	52
K. カム伝導関係.....	20	仕様別部品一覧表.....	55
L. 押エ関係.....	22	ゲージ部品一覧表.....	57
M. 送り関係.....	26	回転数別モータプーリとVベルト組合せ.....	58
N. カッター関係.....	28	索 引.....	59
P. 糸切れ感知関係.....	32		

Notes for using this parts book

1. This book is applicable to sewing machines which have the same plate number as shown on the cover of this book (or correction sheet).
2. This book was prepared based on information available in January 1990.
3. Parts are subject to changes in design without prior notice.
4. If the symbol * is found in the "Parts No." column, refer to the different parts list on page 55.

CONTENTS

A. Machine body	2	Q. Lower shaft mechanism	32
B. Needle bar mechanism	6	R. Rotary hook mechanism	34
C. Upper shaft mechanism	8	S. Lubrication	36
D. Zigzag mechanism	10	T. Threading mechanism	40
E. Clutch mechanism	14	U. Bobbin winder	44
F. Power transmitter mechanism	16	V. Upper thread trimmer mechanism	46
G. Belt shift mechanism	16	W. Lower thread trimmer mechanism	48
H. Emergency stop mechanism	18	Y. Option parts	50
J. Tension pulley mechanism	18	Z. Accessories	52
K. Feed cam mechanism	20	DIFFERENT PARTS LIST	55
L. Presser foot mechanism	22	GAUGE PARTS LIST	57
M. Feed mechanism	26	MOTOR PULLEY AND V-BELT SELECTION	58
N. Cutter mechanism	28	INDEX	59
P. Thread breakage detector mechanism	32		

Anmerkungen zum Gebrauch dieses Stücklistebuches

1. Dieses Buch bezieht sich auf die Nähmaschinen mit derselben Kennungsnummer wie auf diesem Buchumschlag (oder auf dem Korrekturblatt).
2. Dieses Buch basiert auf den Informationen vom Januar 1990.
3. Modelländerungen sind vorbehalten.
4. Dieses Zeichen * in der Spalte "Parts No. (Teil-nummer)" verweist auf die Gesonderte Stückliste auf Seite 55.

INHALTSVERZEICHNIS

A. Maschinengehäuse	2	Q. Untere Welle	32
B. Nadelstangenvorrichtung	6	R. Greifervorrichtung	34
C. Obere Welle	8	S. Schmierung	36
D. Zickzackvorrichtung	10	T. Fadenführungsvorrichtung	40
E. Kupplungsvorrichtung	14	U. Spuler	44
F. Kraftübertragungsvorrichtung	16	V. Oberer Fadenabschneider	46
G. Riemenstellvorrichtung	16	W. Unterer Fadenabschneider	48
H. Abschaltvorrichtung	18	Y. Sonderzubehör	50
J. Spannrolle	18	Z. Zubehör	52
K. Transporteurkurve	20	ZUBEHÖRLISTE	55
L. Stoffdrückerfuß	22	LEHRENLISTE	57
M. Transportvorrichtung	26	AUSWAHL DER RIEMENSCHLEIBEN UND ANTRIEBSRIEMEN	58
N. Abschneidevorrichtung	28	VERZEICHNIS	59
P. Fadenbruchfühler	32		

Notes sur l'utilisation de ce manuel de pièces détachées

1. Ce manuel est destiné aux machines à coudre ayant le même numéro de plaque montré sur la couverture de ce manuel (ou sur la feuille de corrections).
2. Ce manuel a été fait d'après les renseignements valables au mois de Janvier 1990.
3. Les pièces peuvent être sujettes à des modifications sans préavis.
4. Si le symbole * se trouve dans la colonne "Parts No. (N° de pièce)" veuillez la vous référer à la liste de pièces annexe page 55.

TABLE DES MATIERES

A. Corps de la machine 2	Q. Mécanisme de l'arbre inférieur 32
B. Mécanisme de la barre à aiguille 6	R. Mécanisme du crochet rotatif 34
C. Mécanisme de l'arbre supérieur 8	S. Lubrification 36
D. Mécanisme du zigzag 10	T. Mécanisme de l'enfilage 40
E. Mécanisme de l'embrayage 14	U. Mécanisme du bobineur 44
F. Mécanisme du transmetteur 16	V. Mécanisme de la coupe-fil supérieur .. 46
G. Mécanisme du changement de courroie 16	W. Mécanisme de la coupe-fil inférieur ... 48
H. Mécanisme de l'arrêt de secours 18	Y. Pièces en option 50
J. Mécanisme de la poulie de tension 18	Z. Accessoires 52
K. Mécanisme de la came d'entraînement 20	LISTE DES PIÈCES ACCESSOIRES 55
L. Mécanisme du pied presseur 22	LISTE DES PIÈCES D'ECARTEMENT .. 57
M. Mécanisme de l'entraînement 26	MOTEUR ET DES LISTE DES PIÈCES COURROIES TRAPEZOIDALES 58
N. Mécanisme de la coupe 28	INDEX 59
P. Mécanisme du détecteur de cassure du fil 32	

Notas para usar este Libro de Piezas

1. Este libro sirve para todas las máquinas de coser que llevan la misma placa de identificación que la que se puede ver en la tapa de este libro (o en la hoja de erratas).
2. Este libro ha sido compilado basándose en los datos de que se disponía en enero 1990.
3. Las piezas quedan sujetas a cambios de diseño sin aviso previo.
4. De haber un símbolo * junto al "Parts No. (Número de Pieza)", habrá que mirar la lista de piezas separada de la página 55.

INDICE

A. Cuerpo de la máquina	2	Q. Mecanismo del eje inferior	32
B. Mecanismo de la barra de aguja	6	R. Mecanismo del cangrejo	34
C. Mecanismo del eje superior	8	S. Lubricación	36
D. Mecanismo del zigzag	10	T. Mecanismo del enhebrado	40
E. Mecanismo del embrague	14	U. Mecanismo del devanador de la canilla	44
F. Mecanismo del transmisor de potencia	16	V. Mecanismo de la recortadura de hilo superior	46
G. Mecanismo de la traslación de correas	16	W. Mecanismo de la recortadura de hilo inferior	48
H. Mecanismo del parada de emergencia	18	Y. Piezas opcionales	50
J. Mecanismo de la polea de tensión	18	Z. Accesorios	52
K. Mecanismo de la leva de alimentación	20	LISTA DE PIEZAS ACCESORIAS	55
L. Mecanismo del prensatelas	22	LISTA DE PIEZAS DE CALIBRADORES	57
M. Mecanismo de la alimentación	26	ELECCION DE POLEA DE MOTOR Y CORREA TRAPEZOIDAL	58
N. Mecanismo de la corta	28	INDICE	59
P. Mecanismo del sensor de cortes de hilo	32		

A. 主体関係 / Machine body / Maschinengehäuse /
Corps de la machine / Cuerpo de la máquina

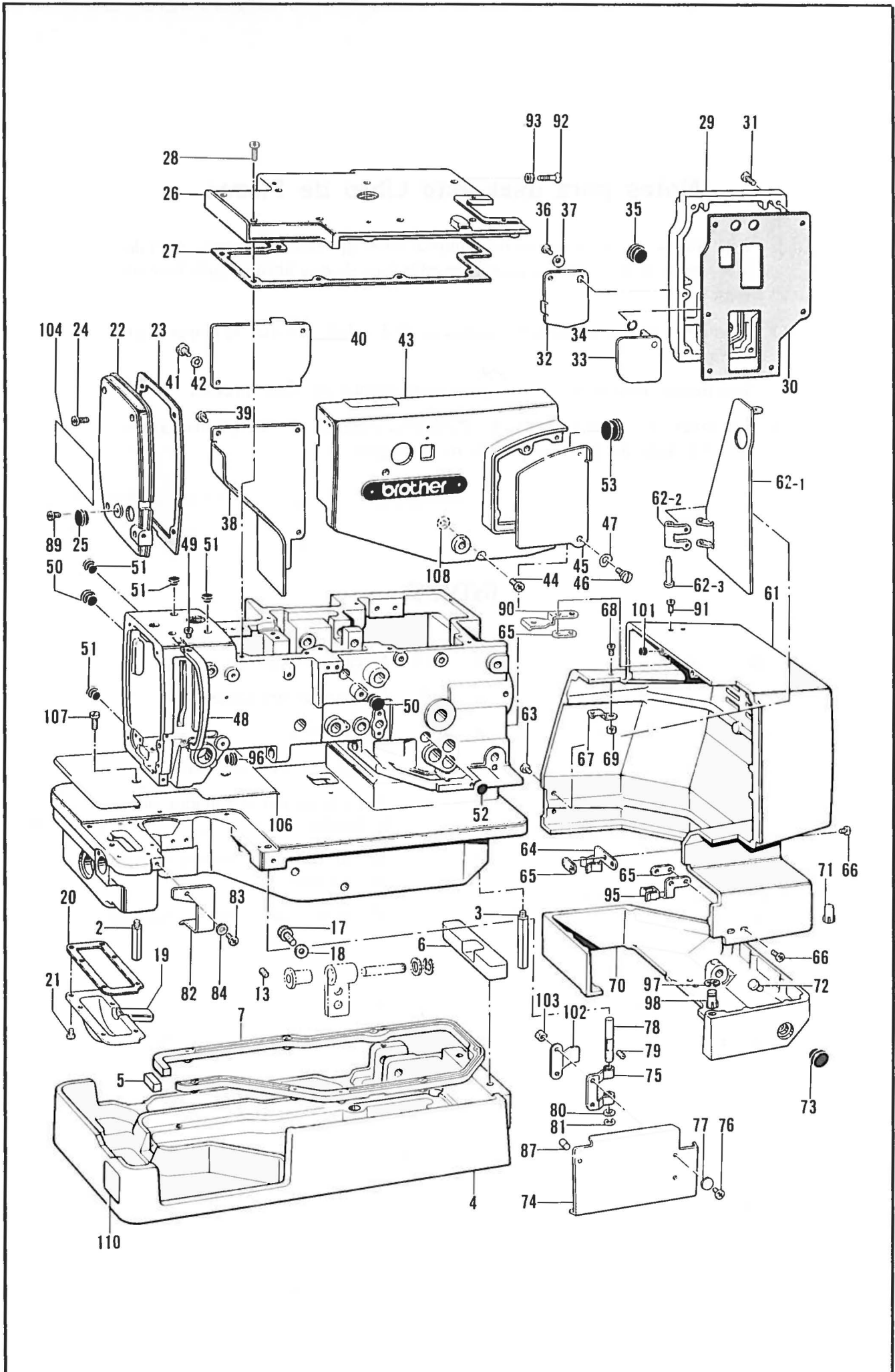

A. 主体関係 / Machine body / Maschinengehäuse /
Corps de la machine / Cuerpo de la máquina

REF. NO.	CODE	Q'TY	ヒンメイ	NAME OF PARTS	RMKS
2	151059001	1	ホンタイシチユウ	MACHINE BODY LEG	
3	113590001	3	ヘ"ツト"アシL	BED LEG (LONG)	
4	158825006	1	ヘ"ツト"タ"イ	BED BASE	
5	S17062000	1	ヘ"ツト"タ"イクツシヨシ	BED BASE CUSHION	
6	159455000	1	ヘ"ツト"クツシヨシR	BED CUSHION (REAR)	
7	S15855000	1	ヘ"ツト"ウケゴム	BED VESSEL RUBBER	
13	014760622	2	アナトメネシ"5.95	SCREW 5.95	
17	018061622	4	アナホ"ルト6X16	BOLT 6X16	
18	025060232	4	ヒラサ"カ"ネチユウ6	WASHER 6	
19	158833001	1	キ"ヤケースカハ"ー	GEAR CASE COVER	
20	158834000	1	キ"ヤケースカハ"ーハ"ツキン	GEAR CASE COVER PACKING	
21	062680812	6	ナヘ"コ437-40X8	SCREW 437X8	
22	158836006	1	メンイタ	FASE PLATE	
23	158837000	1	メンイタハ"ツキン	PACKING	
24	062711412	4	ナヘ"コ4.76-32X14	SCREW 476X14	
25	159150000	1	カマシ"クメクラセン	OIL CAP	
26	158838006	1	ウフフタ	TOP COVER	
27	158839000	1	ウフフタハ"ツキン	TOP COVER PACKING	
28	062711412	8	ナヘ"コ4.76-32X14	SCREW 476X14	
29	158840006	1	ソクメンカハ"ーR	SIDE COVER (REAR)	
30	158841000	1	ソクメンカハ"ーRハ"ツキン	SIDE COVER (REAR) PACKING	
31	062711412	6	ナヘ"コ4.76-32X14	SCREW 476X14	
32	158842001	1	チヨウセツマ"フタ	ADJUSTING WINDOW COVER	
33	158843001	1	チヨウセツマ"フタウラ	ADJUSTING WINDOW INSIDE COVER	
34	081003670	1	Oリング"PW3	O RING PW3	
35	150756000	1	メクラセン	OIL CAP	
36	062670612	1	ナヘ"コ357-40X6	SCREW 357X6	
37	158844001	1	ワンサ"カ"ネ	WASHER	
38	158845006	1	ソクメンカハ"ーF	SIDE COVER (F)	
39	062710812	3	ナヘ"コ476-32X8	SCREW 476X8	
40	158847001	1	キ"ヤケースフタ	GEAR CASE COVER	
41	107321003	1	タ"ンネシ"4.76	STUD SCREW 4.76	
42	107017002	1	ナミハ"ネサ"カ"ネ	WASHER	
43	158849006	1	カムカハ"ー	CAM COVER	
44	062711412	3	ナヘ"コ4.76-32X14	SCREW 476X14	
45	158851001	1	オクリチヨウセツマ"フタ	FEED ADJUSTING WINDOW COVER	
46	107321003	1	タ"ンネシ"4.76	STUD SCREW 4.76	
47	107017002	1	ナミハ"ネサ"カ"ネ	WASHER	
48	158852002	1	テンヒ"ンカハ"ー	THREAD TAKE-UP COVER	
49	062680612	1	ナヘ"コ437-40X6	SCREW 437X6	
50	104449001	2	メクラセン	OIL CAP	
51	104450101	4	メクラセン	OIL CAP	
52	117934001	1	メクラセン	OIL CAP	
53	158882000	1	メクラセン	OIL CAP	
61	158899006	1	ヘ"ルトカハ"ーL	BELT COVER(L)	
62	159594006	1	ヘ"ルトカハ"ーSクミ	BELT COVER ASSEMBLY(S)	
62-1	158866006	1	ヘ"ルトカハ"ーS	BELT COVER(S)	
62-2	158867001	1	ヘ"ルトカハ"ーヒンジ"	BELT COVER HINGE	
62-3	158868001	1	ヒンジ"シ"ク	BELT COVER HINGE SHAFT	
63	062680812	2	ナヘ"コ437-40X8	SCREW 437X8	
64	158864001	1	ヘ"ルトカハ"ーストツハ"A	BELT COVER STOPPER (A)	
65	158865001	3	ストツハ"ウラカ"ネ	WASHER	
66	062680812	4	ナヘ"コ437-40X8	SCREW 437X8	
67	158869001	1	カハ"ーSストツハ"ハ"ネ	BELT COVER (SMALL) STOPPER SPRING	
68	062680812	1	ナヘ"コ437-40X8	SCREW 437X8	
69	021680202	1	ナツト2シユ4.37	NUT 4.37	
70	158870006	1	ヘ"ルトカハ"ータ"イ	BELT COVER BASE	
71	143787001	1	ミゾ"ツキヒ"ン	PIN	
72	158875001	2	シト"ウレハ"ーストツハ"ー	STARTING LEVER STOPPER	
73	159928000	1	メクラセン	OIL CAP	
74	158876001	1	カマカハ"ー	ROTARY HOOK COVER	
75	158877001	1	カマカハ"ーヒンジ"	ROTARY HOOK COVER HINGE	

A. 主体関係 / Machine body / Maschinengehäuse /
Corps de la machine / Cuerpo de la máquina

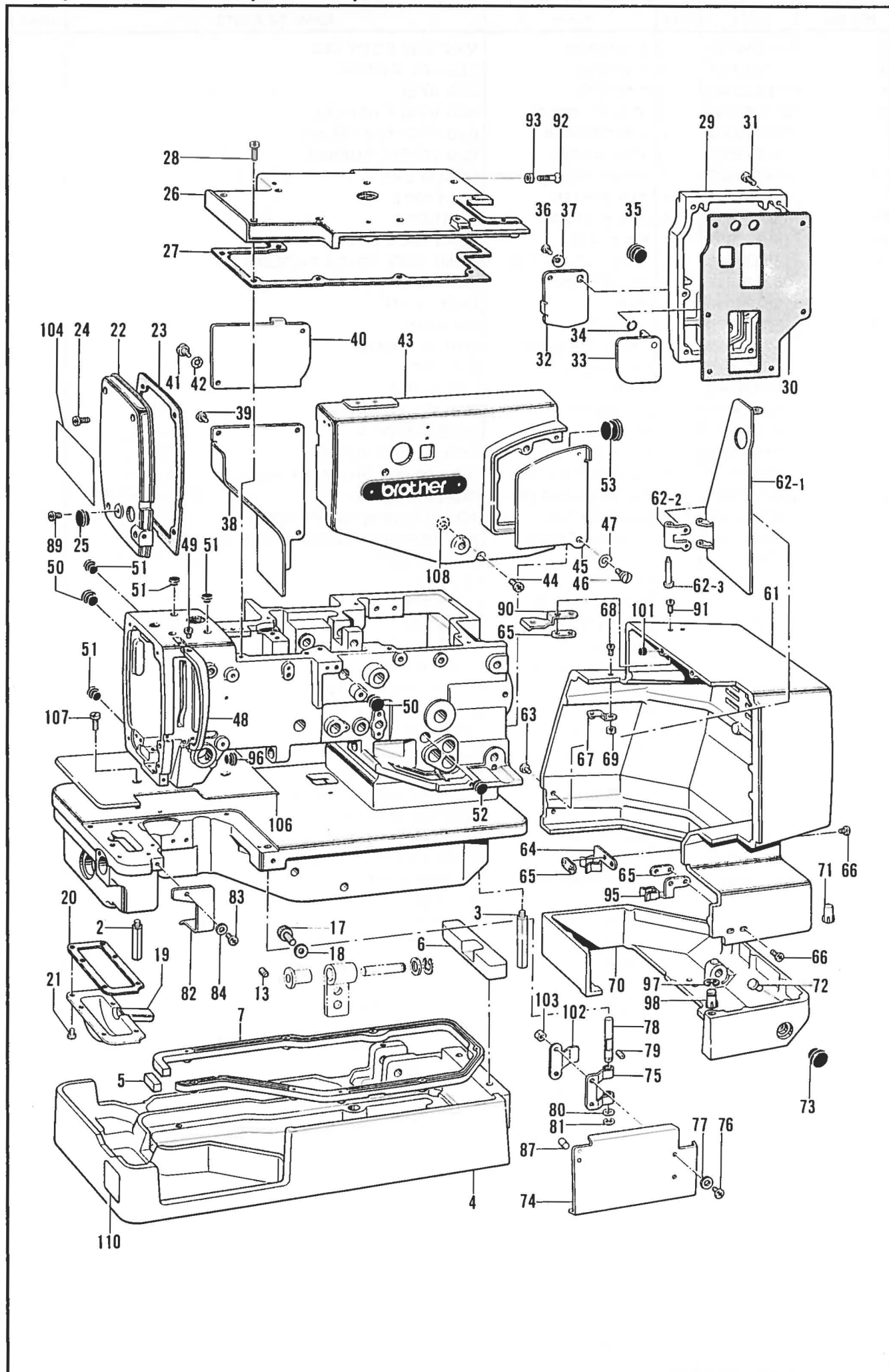

A. 主体関係 / Machine body / Maschinengehäuse /
Corps de la machine / Cuerpo de la máquina

REF. NO.	CODE	Q'TY	ヒンメイ	NAME OF PARTS	RMKS
76	062681012	2	ナヘ"コ437-40X10	SCREW 437X10	
77	025680232	2	ヒラサ"カ"ネチユウ4.37	WASHER 4.37	
78	158879001	1	カマカハ"ー"ジ"ウ	ROTARY HOOK COVER SHAFT	
79	014760622	1	アナトメネシ"5.95	SCREW 5.95	
80	025770232	1	ヒラサ"カ"ネチユウ6.35	WASHER 6.35	
81	048060342	1	トメフE6	STOP RING E6	
82	159595000	1	カマウチカハ"ー	INSIDE COVER	
83	062680612	1	ナヘ"コ437-40X6	SCREW 437X6	
84	025680132	1	ヒラサ"カ"ネシヨウ4.37	WASHER 4.37	
87	S00850000	1	ゴムセン	RUBBER CAP	
89	062710812	2	ナヘ"コ476-32X8	SCREW 476X8	
90	158980001	1	ヘルトカハ"ー"イタハ"ネ	BELT COVER PLATE SPRING	
91	062681212	2	ナヘ"コ437-40X12	SCREW 437X12	
92	141248001	1	ヘルトカハ"ー"ハ"ネウケ	BELT COVER STOPPER	
93	105234003	1	ナツト4.37	NUT 4.37	
95	158969001	1	ヘルトカハ"ー"ストツハ"°B	BELT COVER STOPPER (B)	
96	159928000	1	メクラセン	OIL CAP	
97	048070342	1	トメフE7	STOP RING E7	
98	159989001	1	ミソ"ツキヒンBR8X22	GROOVED PIN 8X22	
101	154578000	1	レハ"ー"ストツハ"°	THREAD TRIMMING LEVER STOPPER	
102	S00306001	1	ヒンシ"イタハ"ネ	SPRING PLATE	
103	021680202	2	ナツト2シユ4.37	NUT 4.37	
104	S01009101	1	イトオシセツツメイイタ	THREADING DIAGRAM	
106	S02974001	1	ヘルツ"カハ"ー"L	BED COVER (LEFT)	
107	107419002	2	シメネシ"4.37	SCREW 4.37	
108	142711001	3	ファイハ"ー"ウツシヤ	WASHER	
110	S14190001	1	カマキユウユセツツメイイタ	DIAGRAM	

B. 針棒關係 / Needle bar mechanism / Nadelstangenvorrichtung /
Mécanisme de la barre à aiguille / Mecanismo de la barra de aguja

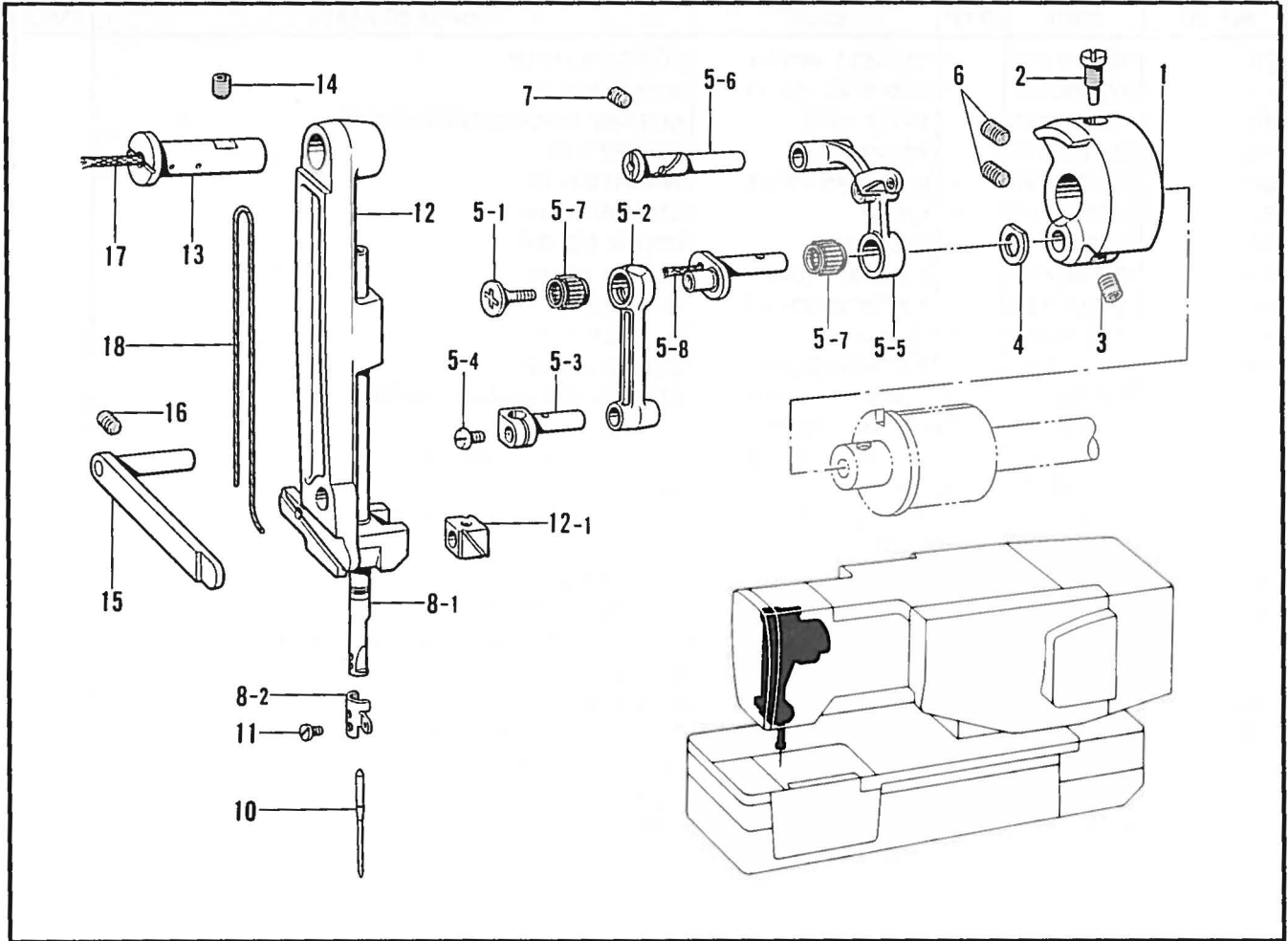

B. 針棒関係 / Needle bar mechanism / Nadelstangenvorrichtung /
 Mécanisme de la barre à aiguille / Mecanismo de la barra de aguja

REF.NO.	CODE	Q'TY	ヒンメイ	NAME OF PARTS	RMKS
1	158880000	1	テンピンクランクA	THREAD TAKE-UP CRANK (A)	
2	100250001	1	シメネジ"7.14	SCREW 7.14	
3	014770622	1	アナトメネジ"6.35クホ"ミ	SCREW 6.35	
4	110367001	1	サ"カ"ネ	WASHER	
5	159409101	1	ハリホ"ウレンカクミ	THREAD TAKE-UP LEVER ASSEMBLY	
5-1	145465001	1	シメネジ"3.57L	SCREW 3.57 (L)	
5-2	S01143001	1	ハリホ"ウクランクロツト"	NEEDLE BAR CRANK ROD	
5-3	111237001	1	ハリホ"ウタ"キ	NEEDLE BAR CLAMP	
5-4	140004001	1	シメネジ"3.57	SCREW 3.57	
5-5	183216101	1	テンピンタイササエクミ	THREAD TAKE-UP LEVER SUPPORTER ASSEMBLY	
5-6	111468001	1	テンピンササエシ"ク	THREAD TAKE-UP LEVER SUPPORTER STUD	
5-7	116735000	2	ニードルベ"アリング"	NEEDLE BEARING	
5-8	140430001	1	クミヒモ	WICK	
6	014770622	2	アナトメネジ"6.35クホ"ミ	SCREW 6.35	
7	014760622	1	アナトメネジ"5.95	SCREW 5.95	
8	158884201	1	ハリホ"ウクミ	NEEDLE BAR ASSEMBLY	
8-1	158885201	1	ハリホ"ウ	NEEDLE BAR	
8-2	159916001	1	ハリホ"ウイトアンナイ	NEEDLE BAR THREAD GUIDE	
10	*	1	ミシンハリ1906	NEEDLE 1906	
11	140553102	1	アタマツキトメネジ"3.18	SCREW 3.18	
12	158886001	1	ハリホ"ウタ"イクミ	NEEDLE BAR SUPPORT ASSEMBLY	
12-1	159624001	1	ハリホ"ウタ"イカクコマ	NEEDLE BAR BRACKET SLIDE BLOCK	
13	158888001	1	ハリホ"ウタ"イササエシ"ク	NEEDLE BAR SUPPORT STUD	
14	014760622	1	アナトメネジ"5.95	SCREW 5.95	
15	158889001	1	ハリホ"ウタ"イアンナイ	NEEDLE BAR SUPPORT GUIDE	
16	014760622	1	アナトメネジ"5.95	SCREW 5.95	
17	159572000	1	クミヒモ	WICK	
18	159561001	1	リアアングミヒモ	WICK	

C. 上軸関係 / Upper shaft mechanism / Obere Welle /
Mécanisme de l'arbre supérieur / Mecanismo del eje superior

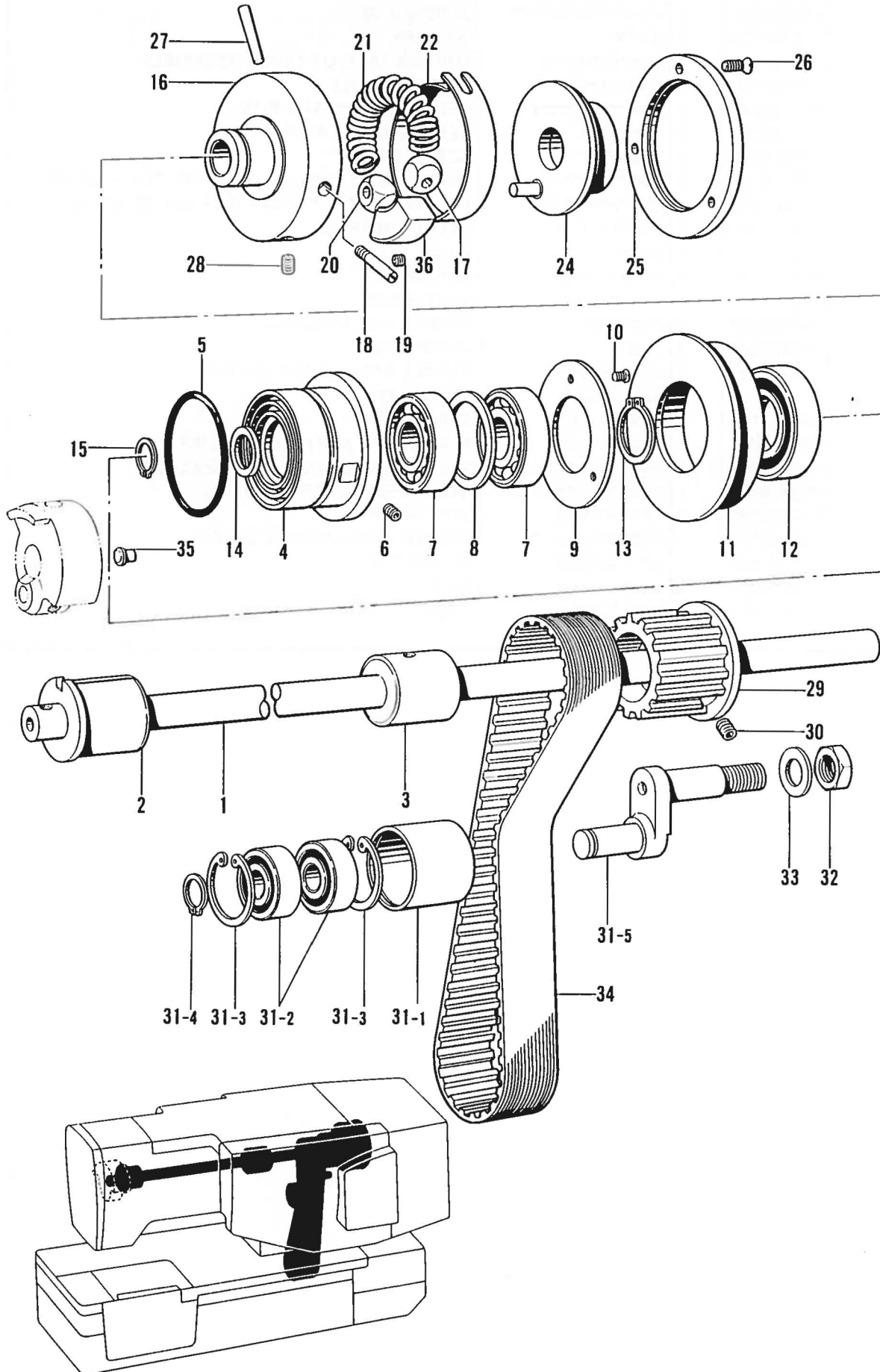

C. 上軸関係 / Upper shaft mechanism / Obere Welle /
Mécanisme de l'arbre supérieur / Mecanismo del eje superior

REF. NO.	CODE	Q'TY	ヒンメイ	NAME OF PARTS	RMKS
1	158891001	1	ウワジ"ク	UPPER SHAFT	
2	158892001	1	ウワジ"クメタルF	UPPER SHAFT BUSHING (FRONT)	
3	158893000	1	ウワジ"クメタルM	UPPER SHAFT BUSHING (MIDDLE)	
4	158894000	1	ヘ"アリング"ケース	BEARING CASE	
5	081048070	1	Oリング"P48	O RING P48	
6	014760622	1	アナトメネジ"5.95	SCREW 5.95	
7	072630260	2	ヘ"アリング"6302VV	BEARING 6302VV	
8	158895001	1	ヘ"アリング"カンザ"	WASHER	
9	158896001	1	ヘ"アリング"フタ	BEARING CAP	
10	102843004	3	サラネジ"3.57	SCREW 3.57	
11	158897001	1	アイト"ラプ"ーリー	IDLER PULLEY	
12	072600560	1	タマジ"クウケ6005VV	BEARING 6005VV	
13	048250142	1	トメワジ"クヨウC25	STOP RING C25	
14	116920001	1	オクリジ"クスラストリング"	THRUST RING	
15	048150142	1	トメワジ"クヨウC15	STOP RING C15	
16	158898001	1	ウワジ"クプ"ーリ	ARM SHAFT PULLEY	
17	159427001	1	ウワジ"クプ"ーリカクコマ	BLOCK FOR PULLEY	
18	159424001	1	プ"ーリカクコマシ"ク	PULLY SHAFT	
19	014679320	1	アナトメネジ"3.57クホ"ミ	SCREW 3.57X3.5	
20	158941001	1	ストツフ"カムカクコマ	BLOCK FOR PULLEY STOP CAM	
21	159425001	1	プ"ーリカンシヨウハ"ネ	PULLEY PLUNGE SPRING	
22	159420001	1	プ"ーリハ"ネカハ"ー	PULLEY INSIDE COVER	
24	158901101	1	ストツフ"カムクミ	STOP CAM ASSEMBLY	
25	158904001	1	ストツフ"カムフタ	CAP FOR STOP CAM	
26	117348001	3	サラネジ"3.57	SCREW 3.57	
27	S01319001	1	テーハ"ピン4X28	TAPER PIN 4X28	
28	014770622	1	アナトメネジ"6.35クホ"ミ	SCREW 6.35	
29	159744100	1	Uタイミング"プ"ーリクミ	TIMING BELT WHEEL UPPER ASSEMBLY	
30	014760622	4	アナトメネジ"5.95クホ"ミ	SCREW 5.95	
31	158906001	1	アイト"ラプ"ーリクミ	IDLER PULLEY ASSEMBLY	
31-1	158907001	1	アイト"ラプ"ーリ	IDLER PULLEY	
31-2	072620260	2	タマジ"クウケ6202VVC2	BEARING 6202VVC2	
31-3	048350242	2	トメワアナヨウC35	STOP RING C35	
31-4	048150142	1	トメワジ"クヨウC15	STOP RING C15	
31-5	158908001	1	アイト"ラプ"ーリウテ"	IDLER PULLEY ARM	
32	158909001	1	ナツト12.7ヒタ"リ	NUT 12.7(L)	
33	025900232	1	ヒラサ"カ"ネチユウ12.70	WASHER 12.70	
34	158910000	1	タイミング"ヘ"ルト	TIMING BELT	
35	111865001	1	オイルメクラセン	OIL CAP	
36	S00862000	1	ストツフ"カムササエ	STOP CAM SUPPORTER	

D. 針振關係 / Zigzag mechanism / Zickzackvorrichtung /
Mécanisme du zigzag / Mecanismo del zigzag

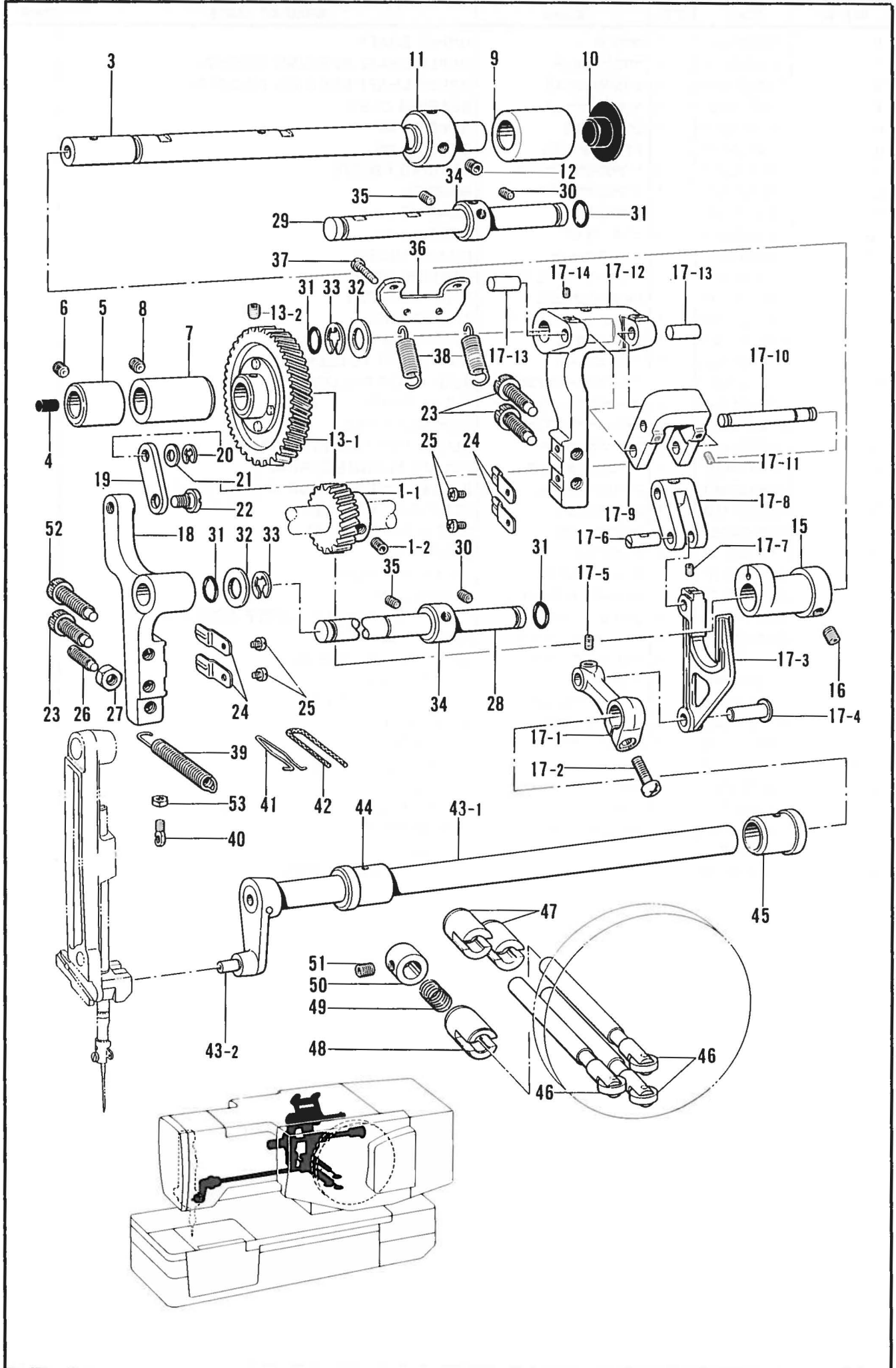

D. 針振関係 / Zigzag mechanism / Zickzackvorrichtung /
Mécanisme du zigzag / Mecanismo del zigzag

REF NO.	CODE	Q'TY	ヒンメイ	NAME OF PARTS	RMKS
1	183702001	1	ゲ"ンソクキ"ヤクミ	SPEED REDUCTION GEAR ASSEMBLY	
1-1	141309001	1	ゲ"ンソクキ"ヤ	SPEED REDUCTION GEAR	
1-2	014770622	2	アナトメネシ"6.35クホ"ミ	SCREW 6.35	
3	158911001	1	フクジ"ク	SUB SHAFT	
4	156641001	2	メクラセン	OIL CAP	
5	158913001	1	フクジ"クメタルF	SUB SHAFT BUSHING (FRONT)	
6	014760622	1	アナトメネシ"5.95	SCREW 5.95	
7	158914001	1	フクジ"クメタルM	SUB SHAFT BUSHING (MIDDLE)	
8	014760622	1	アナトメネシ"5.95	SCREW 5.95	
9	158915001	1	フクジ"クメタルR	SUB SHAFT BUSHING (REAR)	
10	158916000	1	メクラセン	OIL CAP	
11	101486001	1	セツトカラー	SET COLLAR	
12	014760622	2	アナトメネシ"5.95	SCREW 5.95	
13	183707001	1	フクジ"クキ"ヤクミ	SUB SHAFT GEAR ASSEMBLY	
13-1	158917001	1	フクジ"クキ"ヤクミ	SUB SHAFT GEAR	
13-2	014770622	2	アナトメネシ"6.35クホ"ミ	SCREW 6.35	
15	158919101	1	ハリフリカム	ZIGZAG CAM	
16	014770622	2	アナトメネシ"6.35クホ"ミ	SCREW 6.35	
17	159547001	1	ハリフリキクミ	ZIGZAG ADJUSTING CAM ASSEMBLY	
17-1	158947001	1	ハリフリレハ"ーR	ZIGZAG ADJUSTING LEVER (REAR)	
17-2	S01304001	1	シメネシ"6.35X18	SCREW 6.35X18	
17-3	158920001	1	ハリフリフタマタ	ZIGZAG ADJUSTING FORK	
17-4	158921001	1	ハリフリフタマタシ"ク	ZIGZAG ADJUSTING FORK STUD	
17-5	014770622	1	アナトメネシ"6.35クホ"ミ	SCREW 6.35	
17-6	158922001	1	フタマタリンクピン	ZIGZAG ADJUSTING FORK LINK PIN	
17-7	014680622	1	アナトメネシ"4.37クホ"ミ	SCREW 4.37	
17-8	158923001	1	ハリフリリンク	ZIGZAG ADJUSTING LINK	
17-9	158924001	1	キジ"ユニイチヘンカンリンク	LINK	
17-10	158925001	1	ハリフリキシ"ユニシ"ク	ZIGZAG ADJUSTING SHAFT	
17-11	014680622	2	アナトメネシ"4.37クホ"ミ	SCREW 4.37	
17-12	158928000	1	キジ"ユニイチチヨウセツウデ"	ADJUSTING ARM	
17-13	158927001	2	ヘンカンリンクシテンシ"ク	STUD	
17-14	014680622	2	アナトメネシ"4.37クホ"ミ	SCREW 4.37	
18	158932000	1	ハリフリチヨウセツウデ"	ZIGZAG ADJUSTING ARM	
19	158926001	1	フリハハ"ヘンカンリンク	ZIGZAG ADJUSTING LINK	
20	048050342	1	トメフE5	STOP RING E5	
21	153138001	1	サ"カ"ネ	WASHER	
22	145480001	1	タ"ンネシ"6.35	STUD SCREW 6.35	
23	158930001	3	ハリフリチヨウセツネシ"	ZIGZAG ADJUSTING SCREW	
24	158931001	4	ハリフリチヨウセツネシ"オサイ	ZIGZAG ADJUSTING SCREW PRESSER	
25	062680512	4	ナヘ"コ437-40X5	SCREW 437X5	
26	159905001	1	トメヌイチヨウセツネシ"	ADJUSTING SCREW	
27	105812003	1	ナツト7.94	NUT 7.94	
28	158929001	1	チヨウセツウデ"シ"クA	ADJUSTING ARM SHAFT (A)	
29	158933001	1	チヨウセツウデ"シ"クB	ADJUSTING ARM SHAFT (B)	
30	014760622	2	アナトメネシ"5.95	SCREW 5.95	
31	110558001	4	Oリング"	O RING	
32	115007001	2	サ"カ"ネ	WASHER	
33	146293001	2	トメフE10	STOP RING E10	
34	117671002	2	セツトカラー	SET COLLAR	
35	014770622	4	アナトメネシ"6.35クホ"ミ	SCREW 6.35	
36	159426001	1	ハリフリハ"ネカケ	SPRING HOOK	
37	062681612	2	ナヘ"コ437-40X16	SCREW 437X16	
38	158935001	2	ハリフリハ"ネA	SPRING (A)	
39	158939001	1	ハリフリハ"ネB	SPRING (B)	
40	141334001	1	ハ"ネカケ	SPRING HOOK	
41	158940001	1	ハ"ネカケ	SPRING HOOK	
42	159562000	1	クミヒモ	WICK	
43	158942001	1	ハリフリレハ"ーFクミ	ZIGZAG LEVER (FRONT) ASSEMBLY	
43-1	158944001	1	ハリフリレハ"ーシ"ク	ZIGZAG LEVER SHAFT	
43-2	159625001	1	レハ"ーFカクコマシ"ク	ZIGZAG LEVER (FRONT) STUD	
44	158945001	1	ハリフリシ"クメタルF	ZIGZAG LEVER SHAFT BUSHING (FRONT)	

D. 針振関係 / Zigzag mechanism / Zickzackvorrichtung /
 Mécanisme du zigzag / Mecanismo del zigzag

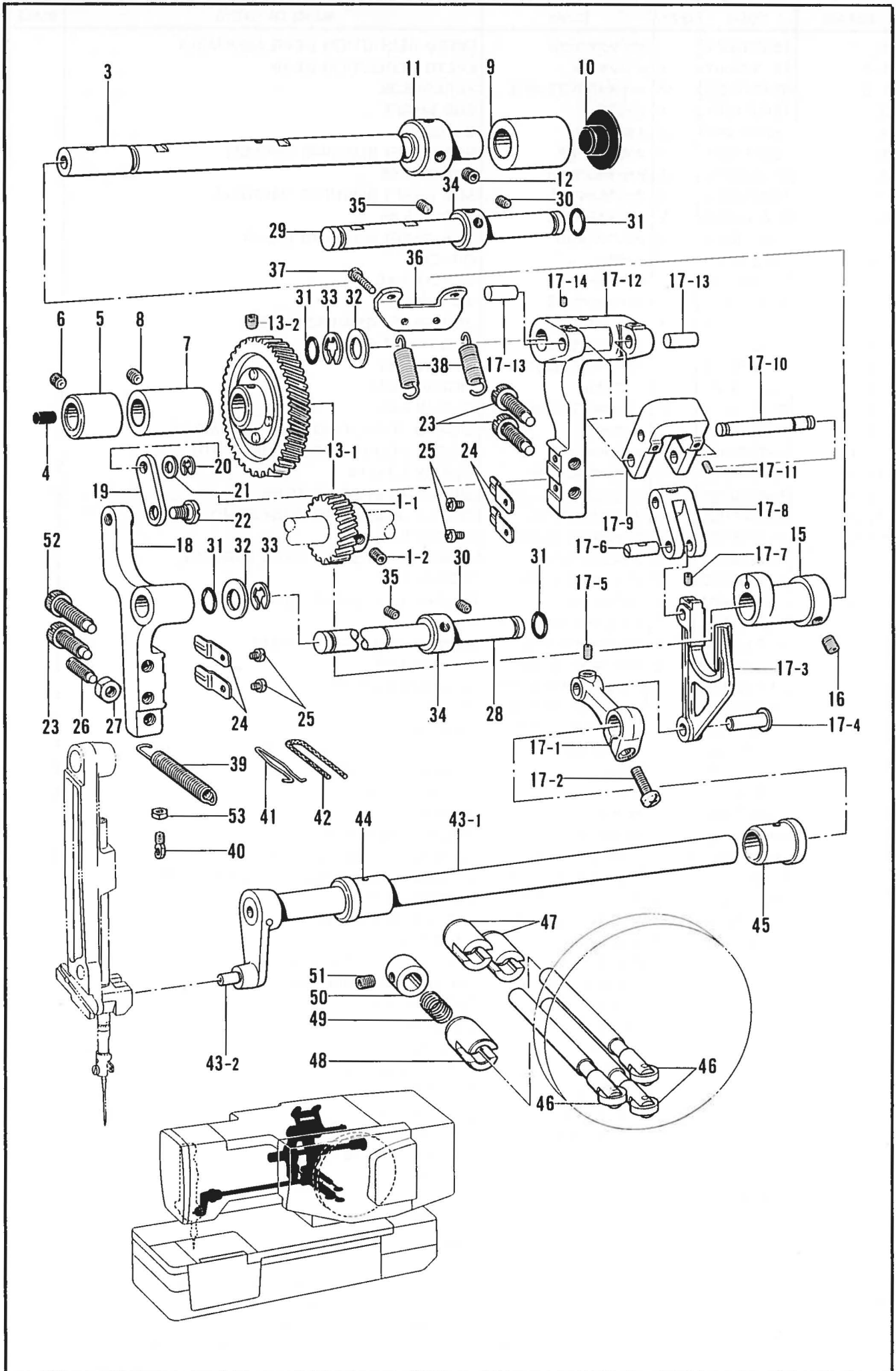

D. 針振関係 / Zigzag mechanism / Zickzackvorrichtung /
 Mécanisme du zigzag / Mecanismo del zigzag

REF.NO.	CODE	Q'TY	ヒンメイ	NAME OF PARTS	RMKS
45	158946001	1	ハリフリシ"クメタルR	ZIGZAG LEVER SHAFT BUSHING (REAR)	
46	158948001	3	ハリフリオシホ"ウクミ	ZIGZAG CONNECTING SHAFT ASSEMBLY	
47	158950000	2	ハリフリオシホ"ウメタル	ZIGZAG ADJUSTING BAR BUSHING	
48	158951000	1	カントメオシホ"ウメタル	BAR TACK ADJUSTING BAR BUSHING	
49	158952001	1	カントメオシホ"ウハ"ネ	SPRING	
50	141351001	1	セツトカラー	SET COLLAR	
51	014770622	1	アナトメネシ"6.35クホ"ミ	SCREW 6.35	
52	159906001	1	カント"メチヨウセツネシ"	BAR TACK ADJUSTING SCREW	
53	100022005	1	ナツト5.95	NUT 5.95	

E. 停止関係 / Clutch mechanism / Kupplungsvorrichtung /
 Mécanisme de l'embrayage / Mecanismo del embrague

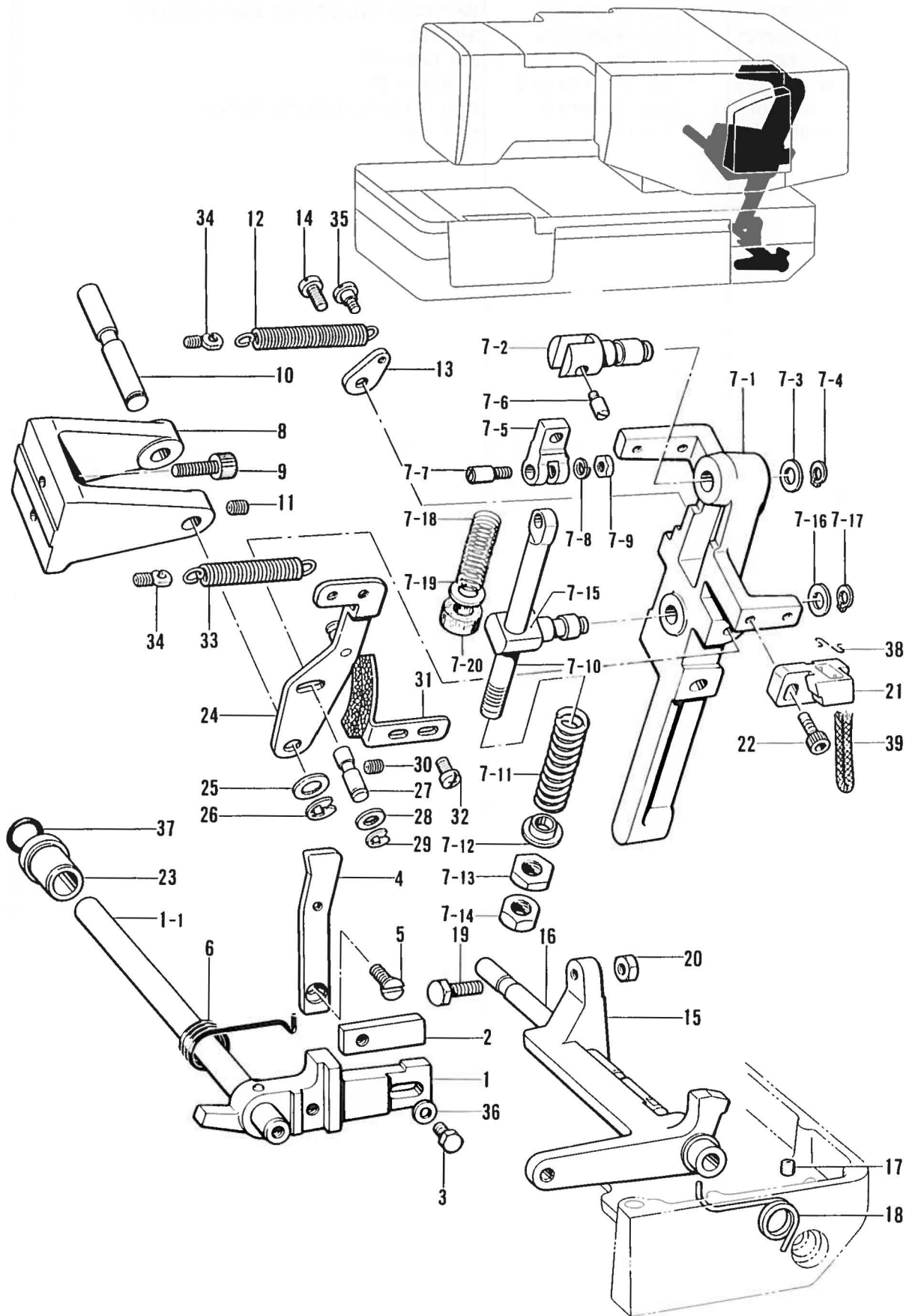

E. 停止関係 / Clutch mechanism / Kupplungsvorrichtung /
Mécánisme de l'embrayage / Mecanismo del embrague

REF.NO.	CODE	Q'TY	ヒンメイ	NAME OF PARTS	RMKS
1	158953001	1	テイシレハークミ	STOP LEVER ASSEMBLY	
1-1	158955001	1	テイシレハークシク	STOP LEVER SHAFT	
2	158956001	1	テイシレハークツメ	STOP LEVER CLAW	
3	017771412	1	ボルト6.35X14	BOLT 6.35X14	
4	158957001	1	テイシカムセツシヨクシ	STOP CAM PLATE	
5	S01698001	1	サラネシ"5.95X12	SCREW 595X12	
6	158958101	1	テイシレハークハネ	STOP LEVER SPRING	
7	159548001	1	クラッチレハークミ	CLUTCH LEVER ASSEMBLY	
7-1	158960001	1	クラッチレハーク	CLUTCH LEVER	
7-2	142667001	1	クラッチストツハ"ササエ	CLUTCH STOPPER SUPPORTER	
7-3	025100132	1	ヒラサ"ガ"ネシヨウ10	WASHER 10	
7-4	048100142	1	トメワシ"クヨウC10	STOP RING C10	
7-5	115545001	1	クラッチストツハ"	CLUTCH STOPPER	
7-6	115544001	1	クラッチストツハ"ササエシク	CLUTCH STOPPER STUD	
7-7	115546001	1	クラッチストツハ"シク	CLUTCH STOPPER STUD	
7-8	028050240	1	ハ"ネサ"ガ"ネ2-5	SPRING WASHER2-5	
7-9	021710202	1	ナット2シユ4.76	NUT 4.76	
7-10	158962001	1	ストツハ"ハ"ネシク	CLUTCH STOPPER SPRING SHAFT	
7-11	158963001	1	ストツハ"オシハ"ネ	CLUTCH STOPPER SPRING	
7-12	158964001	1	ストツハ"ハ"ネカラー	CLUTCH STOPPER SPRING COLLAR	
7-13	021860312	1	ナット3シユ9.52	NUT3-9.52	
7-14	100075004	1	ナット9.52	NUT9.52	
7-15	158965001	1	チヨウセツハ"ネシ"クダ"キ	ADJUSTING BAR CLAMP	
7-16	025100132	1	ヒラサ"ガ"ネシヨウ10	WASHER 10	
7-17	048100142	1	トメワシ"クヨウC10	STOP RING C10	
7-18	115551001	1	ストツハ"オシハ"ネB	SPRING (B)	
7-19	025100132	1	ヒラサ"ガ"ネシヨウ10	WASHER 10	
7-20	115550001	1	フェルト	SPRING FELT	
8	158959001	1	クラッチレハーク"タイ	CLUTCH LEVER BRACKET	
9	018082022	2	アナボルト8X20	BOLT 8X20	
10	158961001	1	クラッチレハーク"シク	CLUTCH LEVER SHAFT	
11	014760622	2	アナメネシ"5.95	SCREW 5.95	
12	S11309001	1	クラッチヒキハ"ネ	SPRING	
13	115558002	1	ハ"ネチヨウセツイタ	ADJUSTING PLATE	
14	062761212	1	ナヘ"コ595-28X12	SCREW 595X12	
15	158968001	1	シト"ウレハーク	STARTING LEVER	
16	158970001	1	シト"ウレハーク"シク	STARTING LEVER SHAFT	
17	014760622	1	アナメネシ"5.95	SCREW 5.95	
18	158971001	1	シト"ウレハーク"モト"シハ"ネ	STARTING LEVER RETURNING SPRING	
19	115585001	1	ボルト7.94	BOLT 7.94	
20	152997001	1	ナット7.94	NUT 7.94	
21	S13727001	1	クラッチツメ	CLUTCH CLAW	
22	018061422	2	アナボルト6X14	BOLT 6X14	
23	158973001	1	テイシレハーク"シク"メタル	STOP LEVER SHAFT BUSHING	
24	158974101	1	ブレーキレハーク	BRAKE LEVER	
25	025100132	1	ヒラサ"ガ"ネシヨウ10	WASHER 10	
26	048100142	1	トメワシ"クヨウC10	STOP RING C10	
27	158975001	1	ブレーキレハーク"ピン	BRAKE LEVER PIN	
28	025080132	1	ヒラサ"ガ"ネシヨウ8	WASHER 8	
29	048060342	1	トメワE6	STOP RING E6	
30	014760622	1	アナメネシ"5.95	SCREW 5.95	
31	158976001	1	ブレーキシュークミ	BRAKE SHOE ASSEMBLY	
32	062760812	2	ナヘ"コ595-28X8	SCREW 595X8	
33	158979001	1	ブレーキハ"ネ	BRAKE SPRING	
34	141334001	2	ハ"ネカケ	SPRING HOOK	
35	115559002	1	ダン"ネシ"4.76	STUD SCREW 4.76	
36	025770232	1	ヒラサ"ガ"ネチヨウ6.35	WASHER 6.35	
37	081010670	1	O"リング"PW10	O RING PW10	
38	116795001	1	クリップ	CLIP	
39	117006001	1	クミヒモ	WICK	

F. 減速関係 / Power transmitter mechanism / Kraftübertragungsvorrichtung /
 Mécanisme du transmetteur / Mecanismo del transmisor de potencia

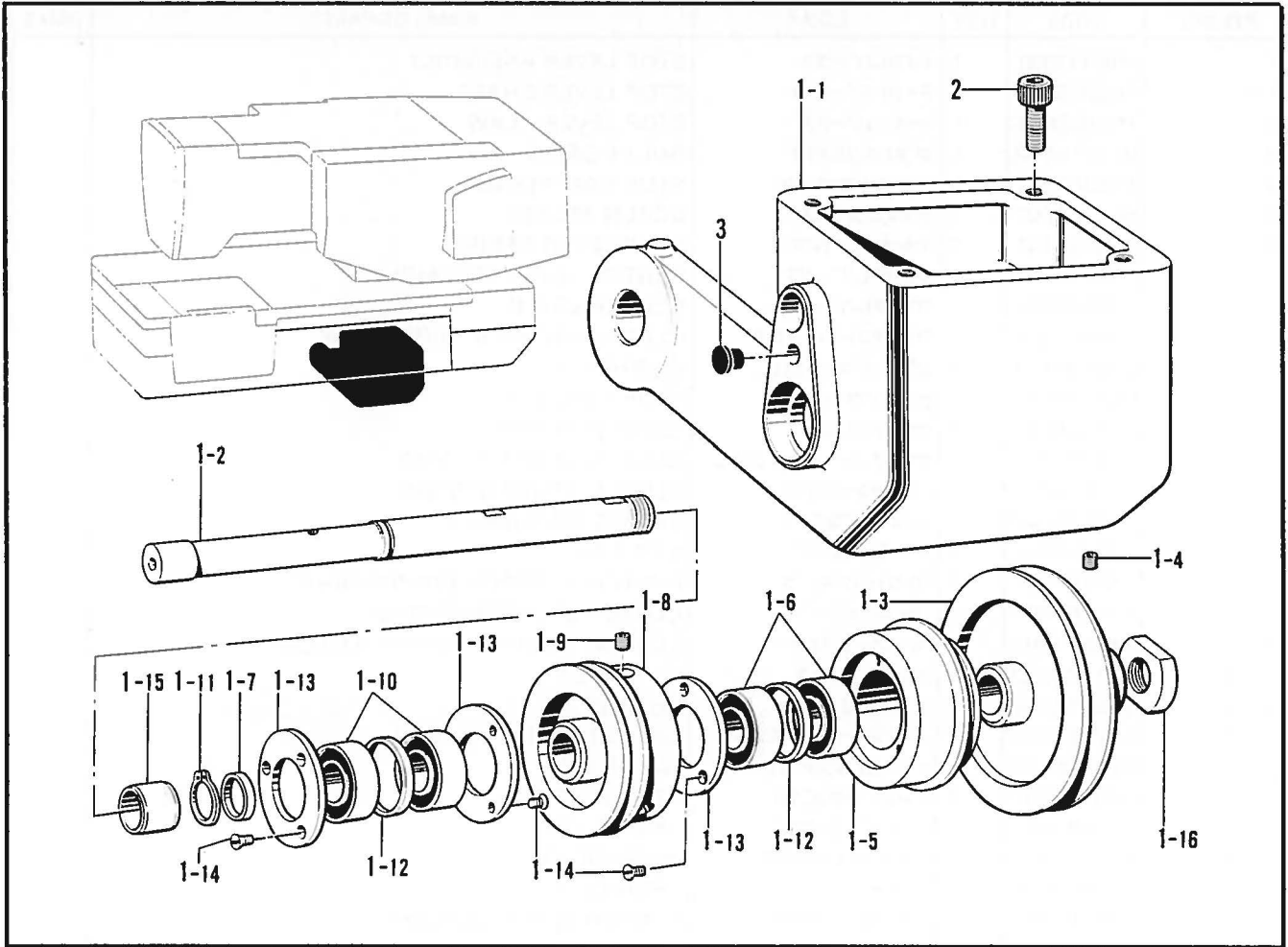

G. ベルト寄せ関係 / Belt shift mechanism / Riemenummstellvorrichtung /
 Mécanisme du changement de courroie / Mecanismo de la traslación de correas

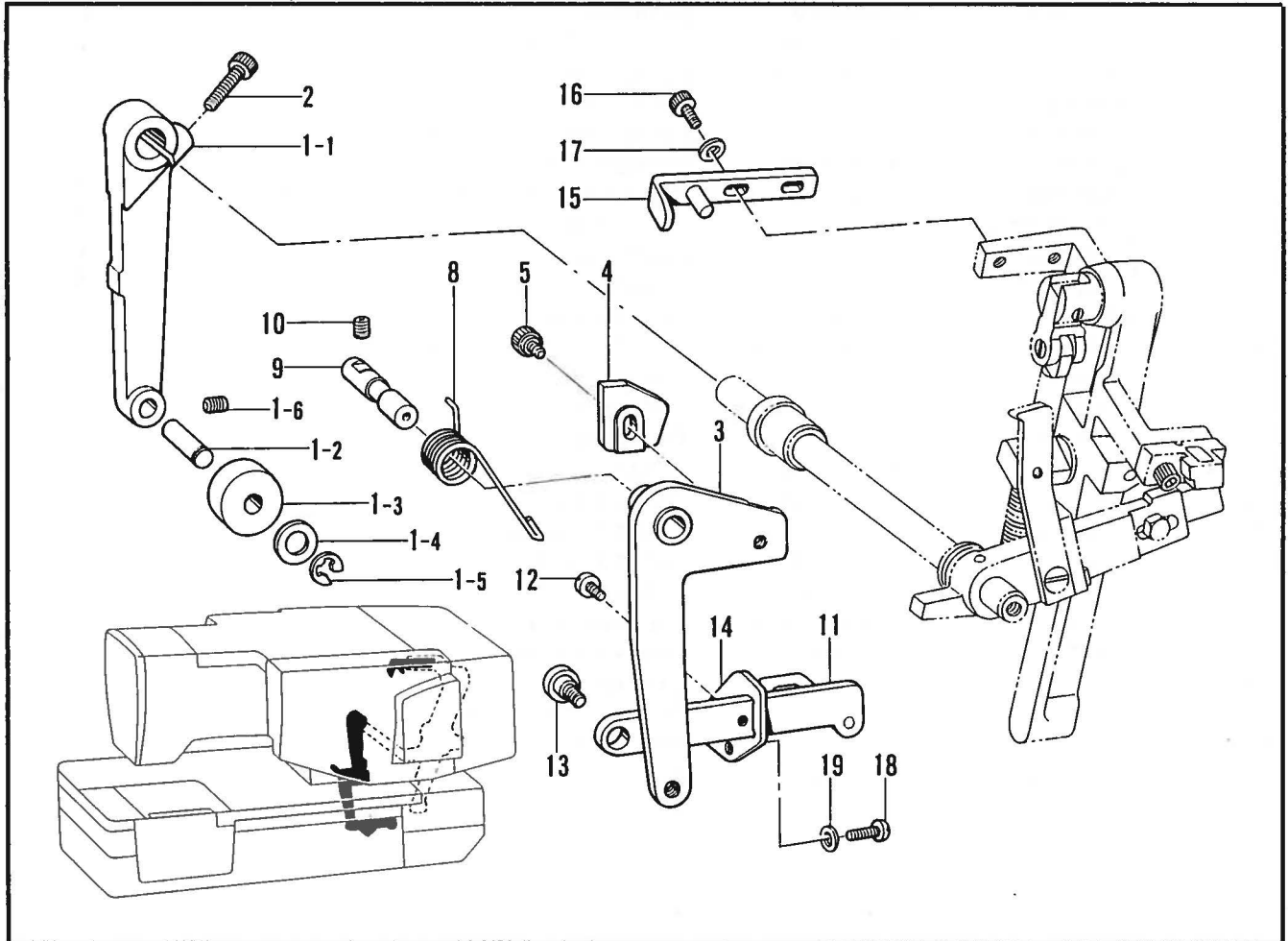

F. 減速関係 / Power transmitter mechanism / Kraftübertragungsvorrichtung /
Mécánisme du transmetteur / Mecanismo del transmisor de potencia

REF.NO.	CODE	Q'TY	ヒンメイ	NAME OF PARTS	RMKS
1	159550101	1	トランスミツタタ"イクミ	TRANSMITER BASE ASSEMBLY	
1-1	S07849001	1	トランスミツタタ"イ	TRANSMITER BESE	
1-2	S07850001	1	トランスミツタシ"ク	TRANSMITER SHAFT	
1-3	158984101	1	テイソクフ"ーリ	SLOW SPEED (V) PULLEY	
1-4	014760622	2	アナトメネシ"5.95	SCREW 5.95	
1-5	S07851001	1	コウソクフ"ーリ	PULLEY	
1-6	072600360	2	タマシ"クウケ6003VV	BEARING 6003VV	
1-7	158986101	1	サ"カ"ネ	WASHER	
1-8	158987101	1	テイソクフ"ーリ	SLOW SPEED PULLEY	
1-9	014760622	2	アナトメネシ"5.95	SCREW 5.95	
1-10	072600360	2	タマシ"クウケ6003VV	BEARING 6003VV	
1-11	048170142	1	トメワシ"クヨウC17	STOP RING C17	
1-12	158981101	2	ハ"アリング"カンザ"	BEARING COLLAR	
1-13	141276001	3	タマシ"クウケフタS	CAP(S)	
1-14	102843004	9	サラネシ"3.57	SCREW 3.57	
1-15	S07852000	1	ト"ライメツトフ"ツシユ	DRY MET BUSH	
1-16	602344001	1	チャツクナツト	CHUCK NUT	
2	018082022	4	アナホ"ルト8X20	BOLT 8X20	
3	104450101	1	メクラセン	OIL CAP	

G. ベルト寄せ関係 / Belt shift mechanism / Riemenumstellvorrichtung /
Mécánisme du changement de courroie / Mecanismo de la traslación de correas

REF.NO.	CODE	Q'TY	ヒンメイ	NAME OF PARTS	RMKS
1	159553001	1	ハ"ルトヨセクト"ウレハ"クミ	BELT SHIFT LEVER ASSEMBLY	
1-1	158990001	1	ハ"ルトヨセクト"ウレハ"ー	BELT SHIFT LEVER	
1-2	158991001	1	ハ"ルトヨセローラシ"ク	BELT SHIFTER ROLLER STUD	
1-3	158992001	1	ハ"ルトヨセローラ	BELT SHIFT ROLLER	
1-4	107153002	1	サ"カ"ネ	WASHER	
1-5	048060342	1	トメワE6	STOP RING E6	
1-6	014760622	1	アナトメネシ"5.95	SCREW 5.95	
2	018062222	1	アナホ"ルト6X22	BOLT 6X22	
3	158993001	1	ハ"ルトヨセレハ"ー	BELT SHIFTER LEVER	
4	158994001	1	ハ"ルトヨセカム	BELT SHIFTER CAM	
5	S01794001	1	アナホ"ルト6.35X8	BOLT 6.35X8	
8	158995001	1	ハ"ルトヨセレハ"ーハ"ネ	BELT SHIFTER LEVER SPRING	
9	158996001	1	ハ"ルトヨセレハ"ージ"ク	BELT SHIFTER LEVER STUD	
10	014760622	1	アナトメネシ"5.95	SCREW 5.95	
11	158997001	1	ハ"ルトヨセシタ	BELT SHIFTER (LOWER)	
12	062710612	1	ナハ"コ476-32X6	SCREW 476X6	
13	158998001	1	タ"ンネシ"6.35	STUD SCREW 6.35	
14	158999100	1	ハ"ルトヨセシタアンナイ	BELT SHIFTER GUIDE	
15	159000101	1	ハ"ルトヨセU	BELT SHIFTER (U)	
16	018061222	2	アナホ"ルト6X12	BOLT 6X12	
17	025060232	2	ヒラサ"カ"ネチユウ6	WASHER 6	
18	107407003	2	シメネシ"4.37	SCREW 4.37	
19	025680132	2	ヒラサ"カ"ネシヨウ4.37	WASHER 4.37	

H. 非常停止関係 / Emergency stop mechanism / Abschaltvorrichtung /
Mécánisme de l'arrêt de secours / Mecanismo del parada de emergencia

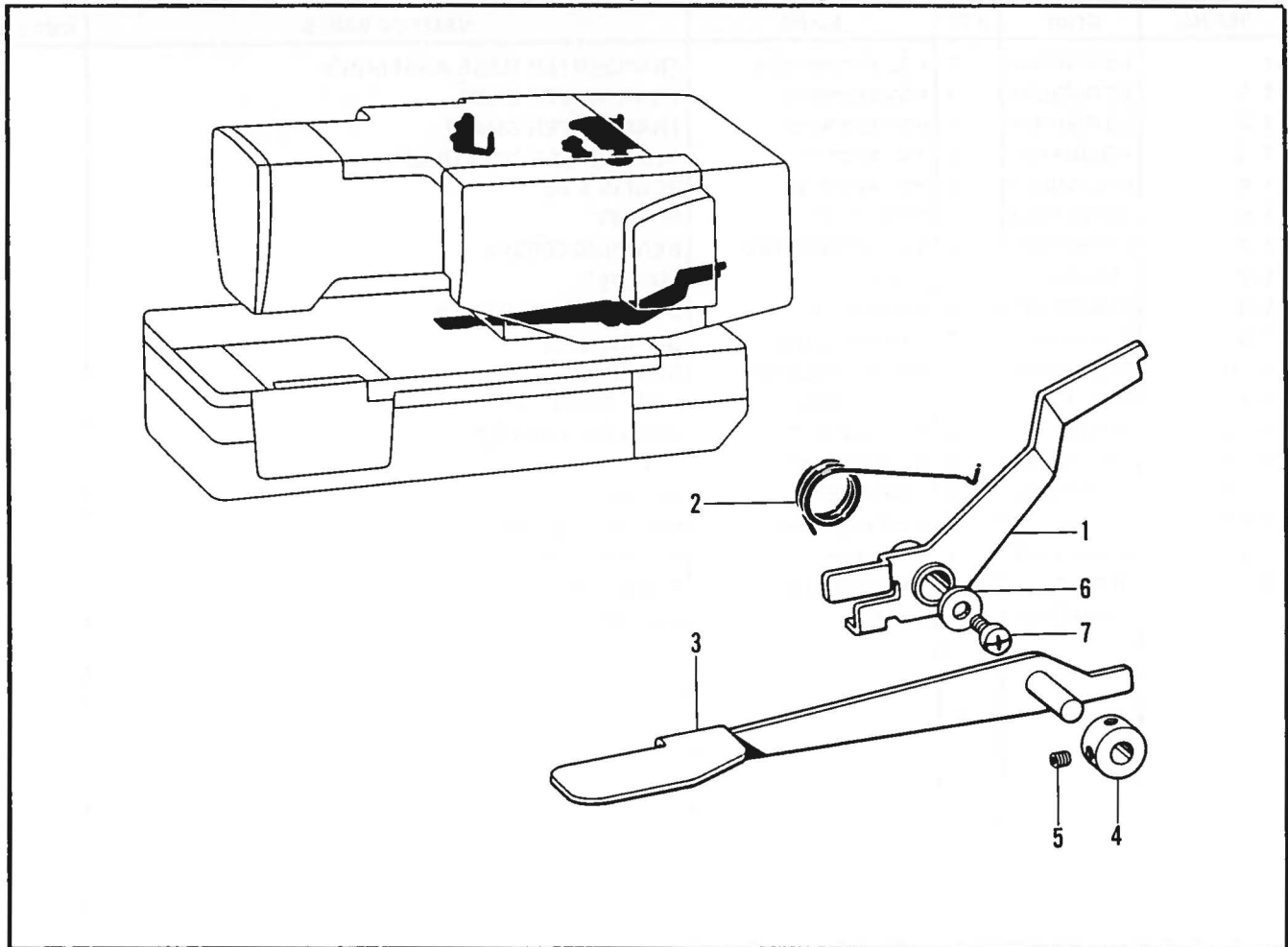

J. テンションプーリ関係 / Tension pulley mechanism / Spannrolle /
Mécánisme de la poulie de tension / Mecanismo de la polea de tensión

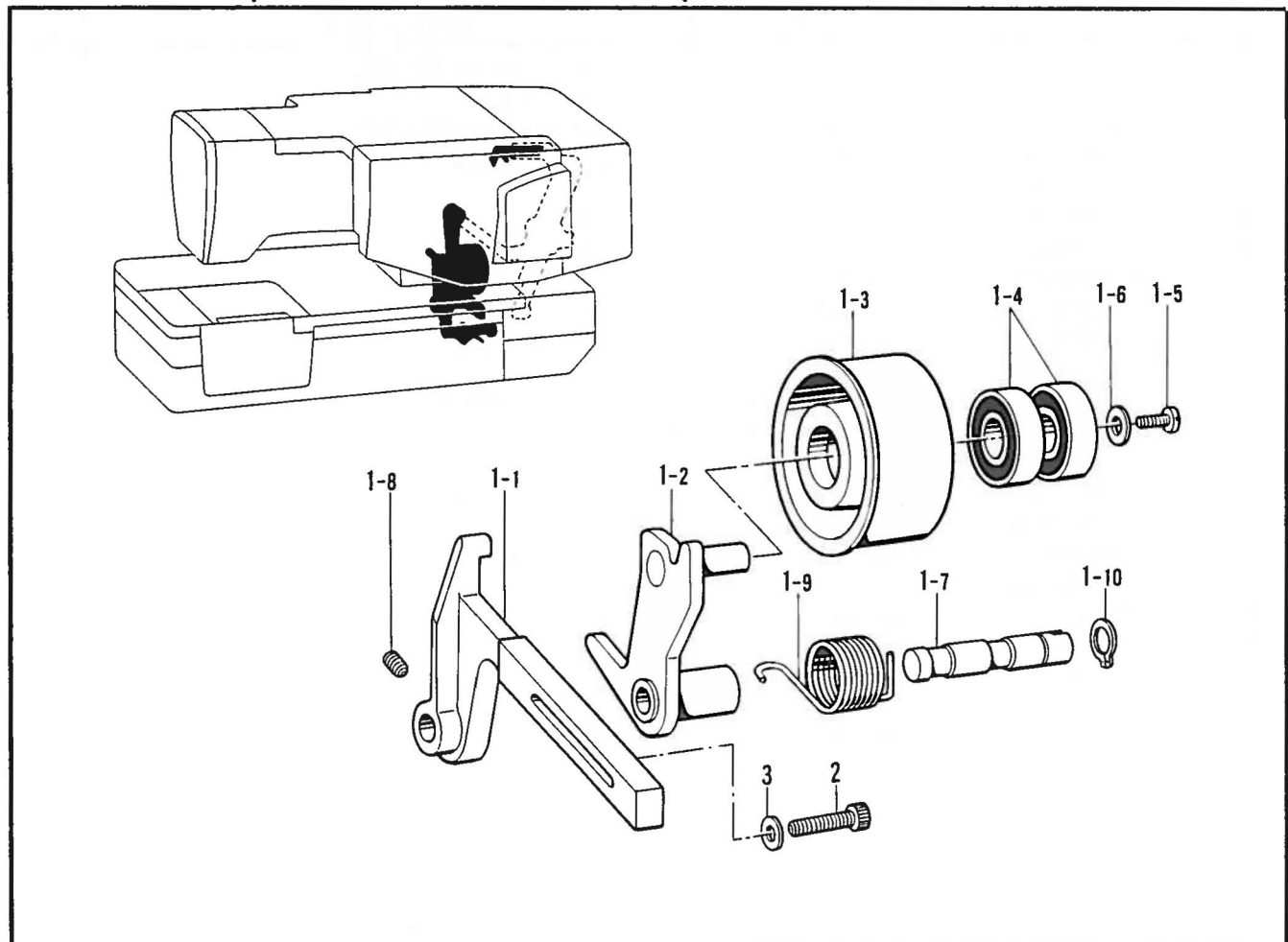

H. 非常停止関係 / Emergency stop mechanism / Abschaltvorrichtung /
 Mécanisme de l'arrêt de secours / Mecanismo del parada de emergencia

REF NO.	CODE	Q'TY	ヒンメイ	NAME OF PARTS	RMKS
1	159001001	1	ヒシ"ヨウテイシレハ"	EMERGENCY STOP LEVR	
2	159002001	1	ヒシ"ヨウテイシレハ"ハ"ネ	EMERGENCY STOP LEVER SPRING	
3	159003001	1	ヒシ"ヨウテイシウテ"クミ	EMERGENCY STOP ARM ASSEMBLY	
4	159006001	1	セツトカラー	SET COLLAR	
5	014680622	2	アナトメネシ"4.37クホ"ミ	SCREW 4.37	
6	025060332	1	ヒラサ"カ"ネタ"イ6	WASHER 6	
7	062771012	1	ナヘ"コ635-40X10	SCREW 6.35X10	

J. テンションプーリ関係 / Tension pulley mechanism / Spannrolle /
 Mécanisme de la poulie de tension / Mecanismo de la polea de tensión

REF.NO.	CODE	Q'TY	ヒンメイ	NAME OF PARTS	RMKS
1	159551001	1	テンションプーリ"クミ	TENSION PULLEY ASSEMBLY	
1-1	159007001	1	テンションプーリ"タ"イ	TENSION PULLEY BRACKET	
1-2	159008001	1	テンションプーリ"ウテ"クミ	TENSION PULLEY ARM ASSEMBLY	
1-3	159011000	1	テンションプーリ	TENSION PULLEY	
1-4	072620160	2	タマシ"クウケ6201VV	BEARING 6201VV	
1-5	062761212	1	ナヘ"コ595-28X12	SCREW 595X12	
1-6	025060332	1	ヒラサ"カ"ネタ"イ6	WASHER 6	
1-7	159012001	1	テンションプーリ"ウテ"シ"ク	TENSION PULLEY ARM SHAFT	
1-8	014760622	1	アナトメネシ"5.95	SCREW 5.95	
1-9	159013001	1	テンションプーリ"ウテ"ハ"ネ	TENSION PULLEY ARM SPRING	
1-10	048100142	1	トメワシ"クヨウC10	STOP RING C10	
2	018082022	1	アナホ"ルト8X20	BOLT 8X20	
3	025080232	1	ヒラサ"カ"ネチユウ8	WASHER 8	

K. カム伝導関係 / Feed cam mechanism / Transporteurkurve /
Mécanisme de la came d'entraînement / Mecanismo de la leva de alimentación

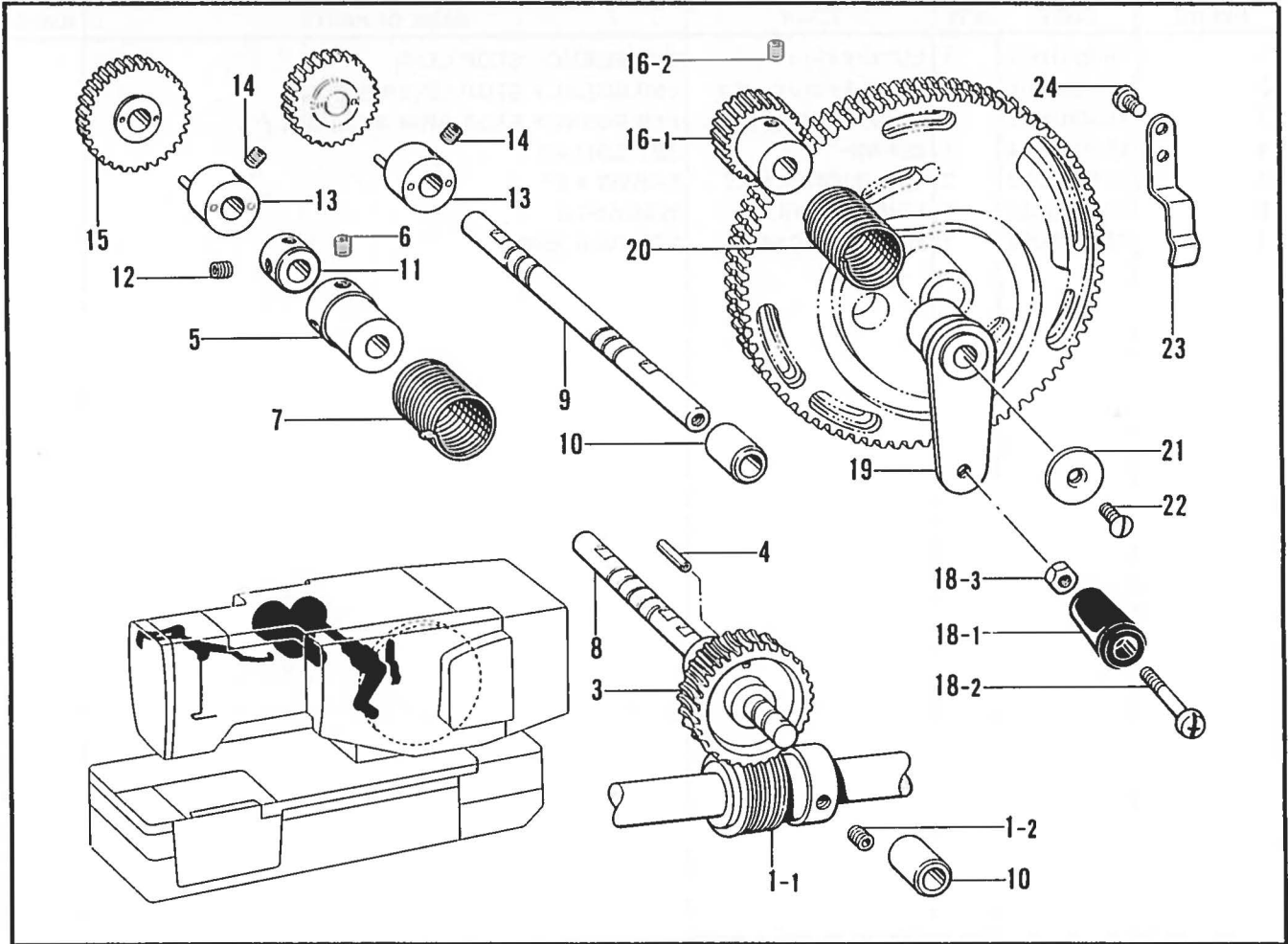

K. カム伝導関係 / Feed cam mechanism / Transporteurkurve /
Mécánisme de la came d'entraînement / Mecanismo de la leva de alimentación

REF.NO.	CODE	Q'TY	ヒンメイ	NAME OF PARTS	RMKS
1	183704001	1	ウオームクミ	WORM ASSEMBLY	
1-1	141367001	1	ウオーム	WORM	
1-2	014770622	2	アナトメネシ"6.35クホ"ミ	SCREW 6.35	
3	159082000	1	ウオームホイール	WORM WHEEL	
4	047301842	1	スフ"リンク"ヒ"ンAW3	SPRING PIN AW3	
5	S13634001	1	ワンウェイクラッチカラー	ONE-WAY CLUTCH COLLAR	
6	014770622	2	アナトメネシ"6.35クホ"ミ	SCREW 6.35	
7	S13635001	1	ワンウェイクラッチハ"ネ	ONE-WAY CLUTCH SPRING	
8	S13633001	1	ウオームホイールシ"ク	WORM WHEEL SHAFT	
9	159086001	1	チェンジ"キ"ヤシ"ク	CHANGE GEAR SHAFT	
10	159087000	2	キ"ヤシ"クメタル	GEAR SHAFT BUSHING	
11	110495003	1	セツトカラー	SET COLLAR	
12	014770622	2	アナトメネシ"6.35クホ"ミ	SCREW 6.35	
13	159088001	2	キ"ヤシ"クカラークミ	GEAR SHAFT COLLAR ASSEMBLY	
14	014770622	4	アナトメネシ"6.35クホ"ミ	SCREW 6.35	
15	*	1	チェンジ"キ"ヤ	GEAR	
16	183708001	1	フリーホイールキ"ヤクミ	FREE WHEEL GEAR ASSEMBLY	
16-1	159090001	1	フリーホイールキ"ヤ	FREE WHEEL GEAR	
16-2	014770622	2	アナトメネシ"6.35クホ"ミ	SCREW 6.35	
18	159091001	1	ハント"ルクミ	HANDLE ASSEMBLY	
18-1	159093000	1	ハント"ル	HANDLE	
18-2	112700001	1	シメネシ"5.95	SCREW 5.95	
18-3	106588003	1	ナツト5.95	NUT 5.95	
19	159092001	1	ハント"ルレハ"ー	HANDLE LEVER	
20	159094001	1	ハント"ルクラッチハ"ネ	HANDLE CLUTCH SPRING	
21	151932001	1	シ"クウケフタ	BEARING COVER	
22	107231002	1	サラネシ"4.76	SCREW 4.76	
23	159095101	1	ハント"ルストツハ°	HANDLE STOPPER	
24	062680612	1	ナヘ"コ437-40X6	SCREW 437X6	

L. 押工関係 / Presser foot mechanism / Stoffdrückerfuß /
 Mécanisme du pied presseur / Mecanismo del prensatelas

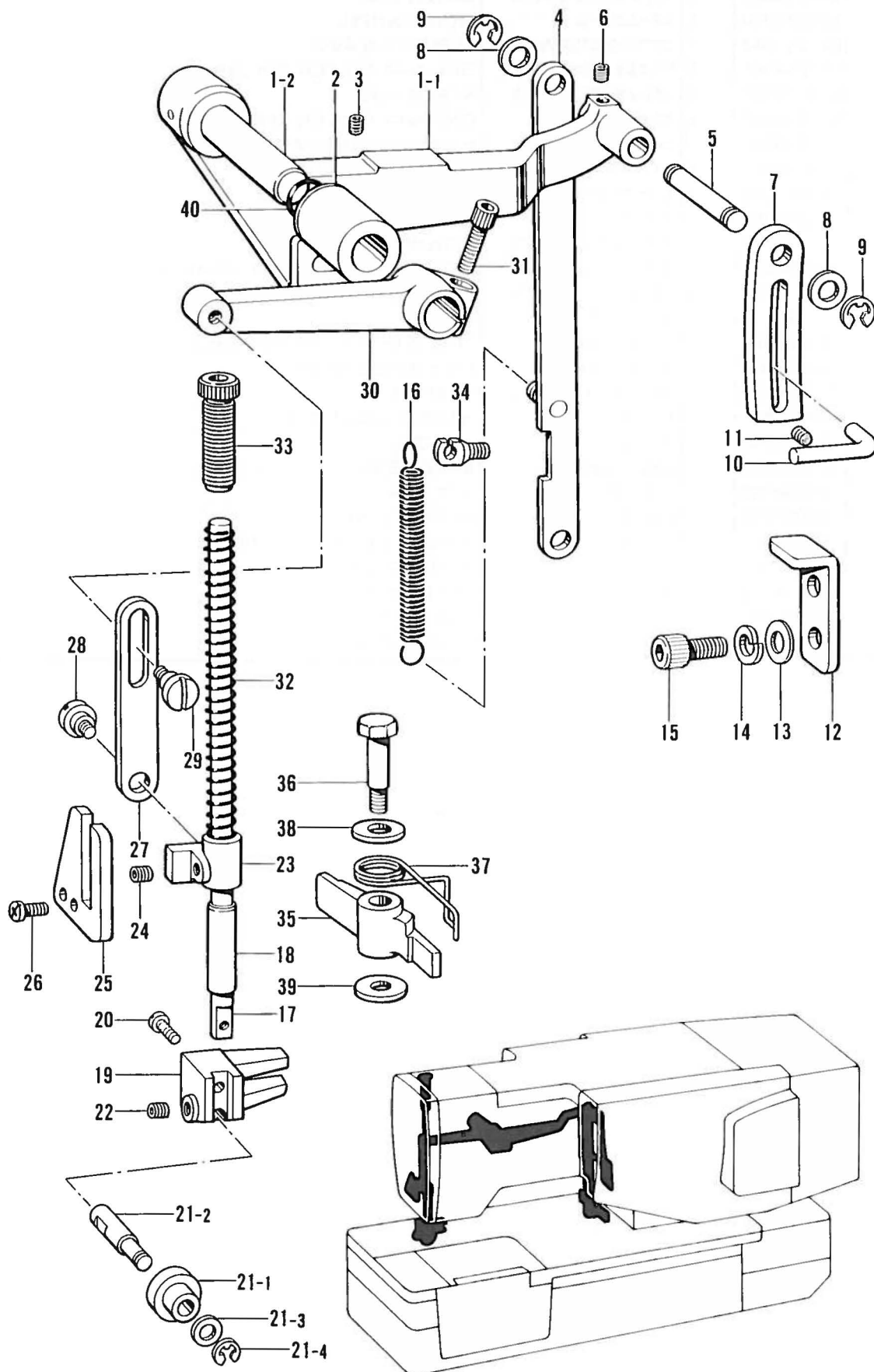

L. 押工関係 / Presser foot mechanism / Stoffdrückerfuß /
 Mécanisme du pied presseur / Mecanismo del prensatelas

REF.NO.	CODE	Q'TY	ヒンメイ	NAME OF PARTS	RMKS
1	159014101	1	オサエアケ"レハ"ークミ	PRESSER LIFTER LEVER ASSEMBLY	
1-1	159015101	1	オサエアケ"レハ"ー	PRESSER LIFTER LEVER	
1-2	159016001	1	オサエアケ"レハ"ーシ"ク	PRESSER LIFTER LEVER SHAFT	
2	159032000	1	オサエレハ"ーシ"クメタル	BUSHING	
3	014760622	1	アナトメネシ"5.95	SCREW 5.95	
4	159018001	1	オサエアケ"レンカン	PRESSER LIFTER DRIVING CONNECTOR	
5	159020001	1	オサエレンカンシ"ク	PRESSER LIFTER DRIVING CONNECTOR STUD	
6	014760622	1	アナトメネシ"5.95	SCREW 5.95	
7	159021001	1	オサエアケ"アンゼ"ンイタ	SAFETY STOPPER	
8	025080232	2	ヒラサ"ガ"ネチユウ8	WASHER 8	
9	048060342	2	トメフE6	STOP RING E6	
10	159022001	1	アンゼ"ンイタシ"ク	SAFETY STOPPER SHAFT	
11	014760622	1	アナトメネシ"5.95	SCREW 5.95	
12	159023001	1	アンゼ"ンイタストツハ"	SAFETY PLATE STOPPER	
13	025080232	2	ヒラサ"ガ"ネチユウ8	WASHER 8	
14	028080242	2	ハ"ネサ"ガ"ネ2-8	SPRING WASHER 2-8	
15	018081622	2	アナホ"ルト8X16	BOLT 8X16	
16	159024001	1	オサエアケ"レンカンハ"ネ	PRESSER LIFTER DRIVING CONNECTOR SPRING	
17	159025001	1	オサエホ"ウ	PRESSER BAR	
18	159818001	1	オサエホ"ウメタル	PRESSER BAR BUSHING	
19	159026001	1	オサエロー"ラタイ	PRESSER BAR ROLLER BRACKET	
20	062681212	1	ナヘ"コ437-40X12	SCREW 437X12	
21	159552001	1	オサエロー"ラクミ	PRESSER BAR ROLLER BRACKET ASSEMBLY	
21-1	159027001	1	オサエロー"ラ	PRESSER ROLLER	
21-2	159028001	1	オサエロー"ラシ"ク	PRESSER ROLLER STUD	
21-3	025060132	1	ヒラサ"ガ"ネシヨウ6	WASHER 6	
21-4	048040342	1	トメフE4	STOP RING E4	
22	014770622	1	アナトメネシ"6.35クホ"ミ	SCREW 6.35	
23	159030000	1	オサエホ"ウタ"キ	PRESSER BAR CLAMP	
24	014760622	1	アナトメネシ"5.95	SCREW 5.95	
25	159031001	1	オサエアンナイイタ	PRESSER BAR CLAMP GUIDE PLATE	
26	062680812	2	ナヘ"コ437-40X8	SCREW 437X8	
27	159033001	1	オサエアケ"リンク	PRESSER LIFTER LINK	
28	159394001	1	タ"ンネシ"5.95	STUD SCREW 5.95	
29	145480001	1	タ"ンネシ"6.35	STUD SCREW 6.35	
30	159034000	1	オサエアケ"レハ"ーテコ	PRESSER BAR LIFTER LEVER	
31	018062022	1	アナホ"ルト6X20	BOLT 6X20	
32	159035001	1	オサエハ"ネ	PRESSER SPRING	
33	100279101	1	オサエチヨウセツネシ"	PRESSER ADJUSTING SCREW	
34	141334001	1	ハ"ネカケ	SPRING HOOK	
35	159923001	1	オサエストツフ"レハ"ー	PRESSER STOP LEVER	
36	159924001	1	ストツフ"レハ"ータ"ンネシ"	PRESSER STOP LEVER STUD SCREW	
37	159925001	1	オサエストツフ"レハ"ーハ"ネ	PRESSER STOP LEVER SPRING	
38	159947001	1	ストツフ"レハ"ーサ"ガ"ネ	WASHER	
39	149095001	1	サ"ガ"ネ	WASHER	
40	081011670	1	Oリング"PW11	O RING PW11	

M. 送り関係 / Feed mechanism / Transportvorrichtung /
 Mécanisme de l'entraînement / Mecanismo de la alimentación

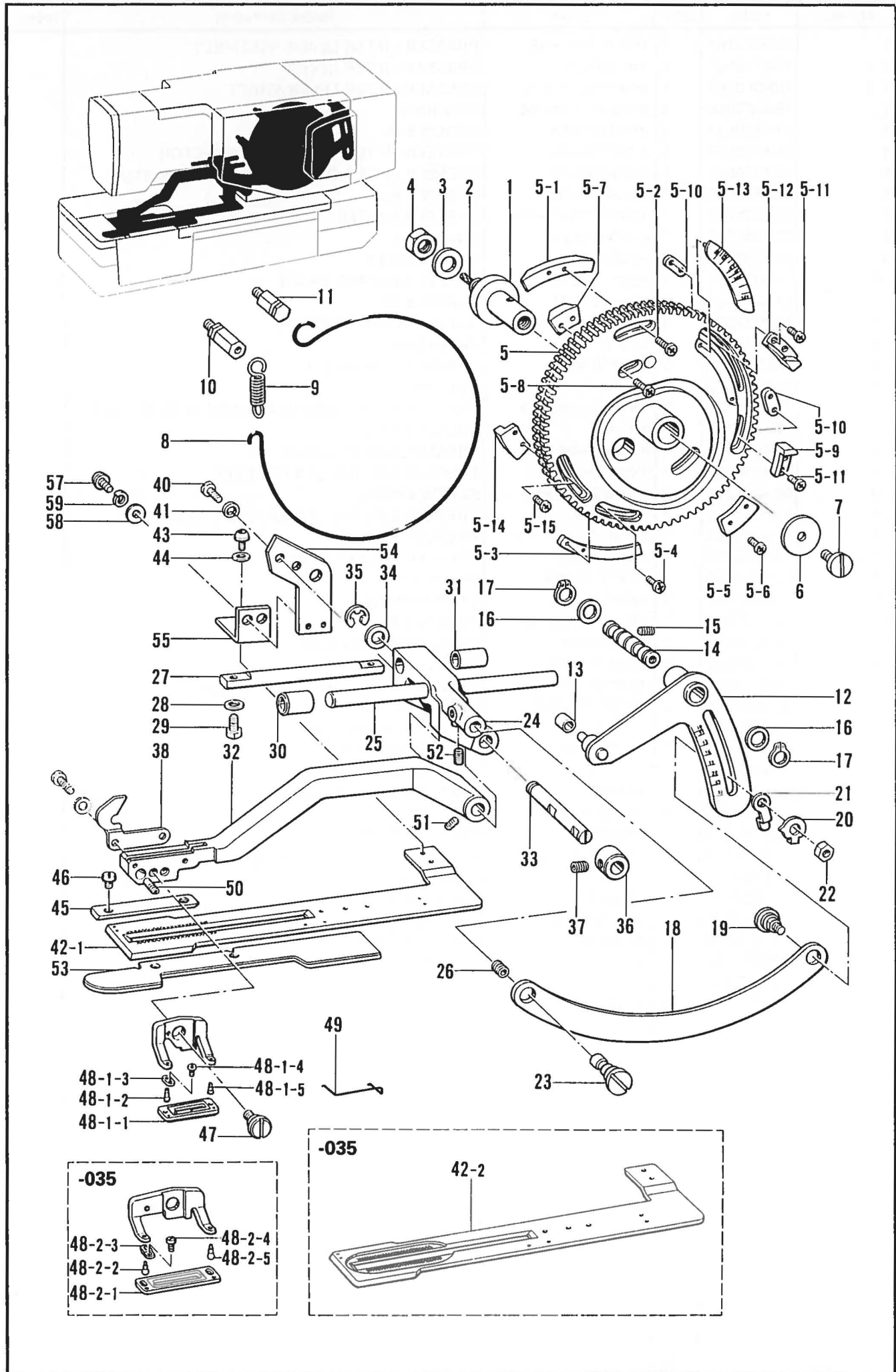

M. 送り関係 / Feed mechanism / Transportvorrichtung /
Mécanisme de l'entraînement / Mecanismo de la alimentación

REF NO.	CODE	Q'TY	ヒンメイ	NAME OF PARTS	RMKS
1	159036001	1	オクリカムシ"ク	FEED CAM SHAFT	
2	159563000	1	クミヒモ	WICK	
3	025900232	1	ヒラサ"カ"ネチユウ12.70	WASHER 12.70	
4	021910302	1	ナツト3シユ12.70	NUT 12.70	
5	159037101	1	オクリカムAクミ	FEED CAM ASSEMBLY (A)	
5-1	159039101	1	イトユルメカムヘンF	THREAD RELEASE CAM SEGMENT (F)	
5-2	062681212	2	ナヘ"コ437-40X12	SCREW 437X12	
5-3	159040101	1	イトユルメカムヘンB	THREAD RELEASE CAM SEGMENT (B)	
5-4	062681212	2	ナヘ"コ437-40X12	SCREW 437X12	
5-5	159041101	1	カント"メカムヘンF	BAR TACK CAM SEGMENT (F)	
5-6	062681012	2	ナヘ"コ437-40X10	SCREW 437X10	
5-7	159042101	1	カント"メカムヘンB	BAR TACK CAM SEGMENT (B)	
5-8	062681012	2	ナヘ"コ437-40X10	SCREW 437X10	
5-9	159043001	1	テイシカムヘンA	STOP CAM SEGMENT (A)	
5-10	159044001	2	テイシカムヘンBサ"カ"ネ	WASHER	
5-11	062681012	4	ナヘ"コ437-40X10	SCREW 437X10	
5-12	159045001	1	テイシカムヘンB	STOP CAM SEGMENT (B)	
5-13	159070001	1	ケ"ソクシシ"イタ	MODERATION INDECATATE PLATE	
5-14	159046001	1	カツタカムヘン	CUTTER CAM SEGMENT	
5-15	062681212	2	ナヘ"コ437-40X12	SCREW 437X12	
6	141400001	1	サ"カ"ネ	WASHER	
7	141408001	1	シメネシ"ヒタ"リ5.95	SCREW 5.95	
8	159047001	1	オクリカムフ"レーキワイヤ	FEED CAM BRAKE WIRE	
9	159048001	1	フ"レーキワイヤヒキハ"ネ	FEED CAM BRAKE WIRE SPRING	
10	159049001	1	フ"レーキワイヤササEA	BRAKE WIRE HOOK (A)	
11	159050001	1	フ"レーキワイヤササEB	BRAKE WIRE HOOK (B)	
12	159051101	1	オクリチヨウセツレハ"ークミ	FEED ADJUSTING LEVER ASSEMBLY	
13	107550002	1	コロ	ROLLER	
14	159054001	1	オクリチヨウセツレハ"ーシ"ク	LENGTH FEED ADJUSTING LEVER SHAFT	
15	014760622	1	アナトメネシ"5.95	SCREW 5.95	
16	142628001	2	スイヘイオクリクランク"リング"	HORIZONTAL FEED CRANK RING	
17	048110142	3	トメワシ"クヨウC11	STOP RING C11	
18	159055001	1	オクリレンカン	FEED CONNECTOR	
19	159056001	1	タ"ンネシ"6.35	STUD SCREW 6.35	
20	159057001	1	メモリスシ"イタ	LENGTH FEED INDICATOR PLATE	
21	159058101	1	メモリストツハ"A	INDICATOR PLATE STOPPER (A)	
22	152750001	1	オクリチヨウセツナツト	NUT	
23	S01236001	1	オクリレンカンシ"ク	FEED CONNECTOR SHAFT	
24	S13652006	1	オクリウテ"シテン	FEED ARM BRACKET	
25	159062001	1	オクリアンナイシ"クA	FEED GUIDE SHAFT (A)	
26	014760622	1	アナトメネシ"5.95	SCREW 5.95	
27	159063001	1	オクリアンナイシ"クB	FEED GUIDE SHAFT (B)	
28	025710232	1	ヒラサ"カ"ネチユウ4.76	WASHER 4.76	
29	017711412	2	ボ"ルト4.76X14	BOLT 4.76X14	
30	159064000	1	オクリアンナイシ"クAメタル	FEED GUIDE SHAFT A BUSHING	
31	142374000	2	DUフ"シユ	BUSHING	
32	159065006	1	ナカ"サオクリウテ"	LENGTH FEED ARM	
33	S13651001	1	ナカ"サオクリウテ"シ"ク	LENGTH FEED ARM SHAFT	
34	025100132	1	ヒラサ"カ"ネシヨウ10	WASHER 10	
35	048080342	1	トメワE8	STOP RING E8	
36	110495003	1	セツトカラー	SET COLLAR	
37	014770622	2	アナトメネシ"6.35クホ"ミ	SCREW 6.35	
38	159067001	1	オクリウテ"ササE	FEED ARM SUPPORTER	
40	062711412	2	ナヘ"コ4.76-32X14	SCREW 476X14	
41	028050242	2	ハ"ネサ"カ"ネ2-5	SPRING WASHER 2-5	
42-1	159069001	1	ナカ"サオクリイタ(-025)	LENGTH FEED PLATE (-025)	
42-2	S01470001	1	ナカ"サオクリイタ(-035)	LENGTH FEED PLATE (-035)	
43	153057002	2	オクリイタシメネシ"	FEED PLATE SCREW	
44	025680232	2	ヒラサ"カ"ネチユウ4.37	WASHER 4.37	
45	159071101	1	ナカ"サオクリイタアンナイ	LENGTH FEED GUIDE PLATE	
46	106568003	4	シメネシ"3.57	SCREW 3.57	

M. 送り関係 / Feed mechanism / Transportvorrichtung /
 Mécanisme de l'entraînement / Mecanismo de la alimentación

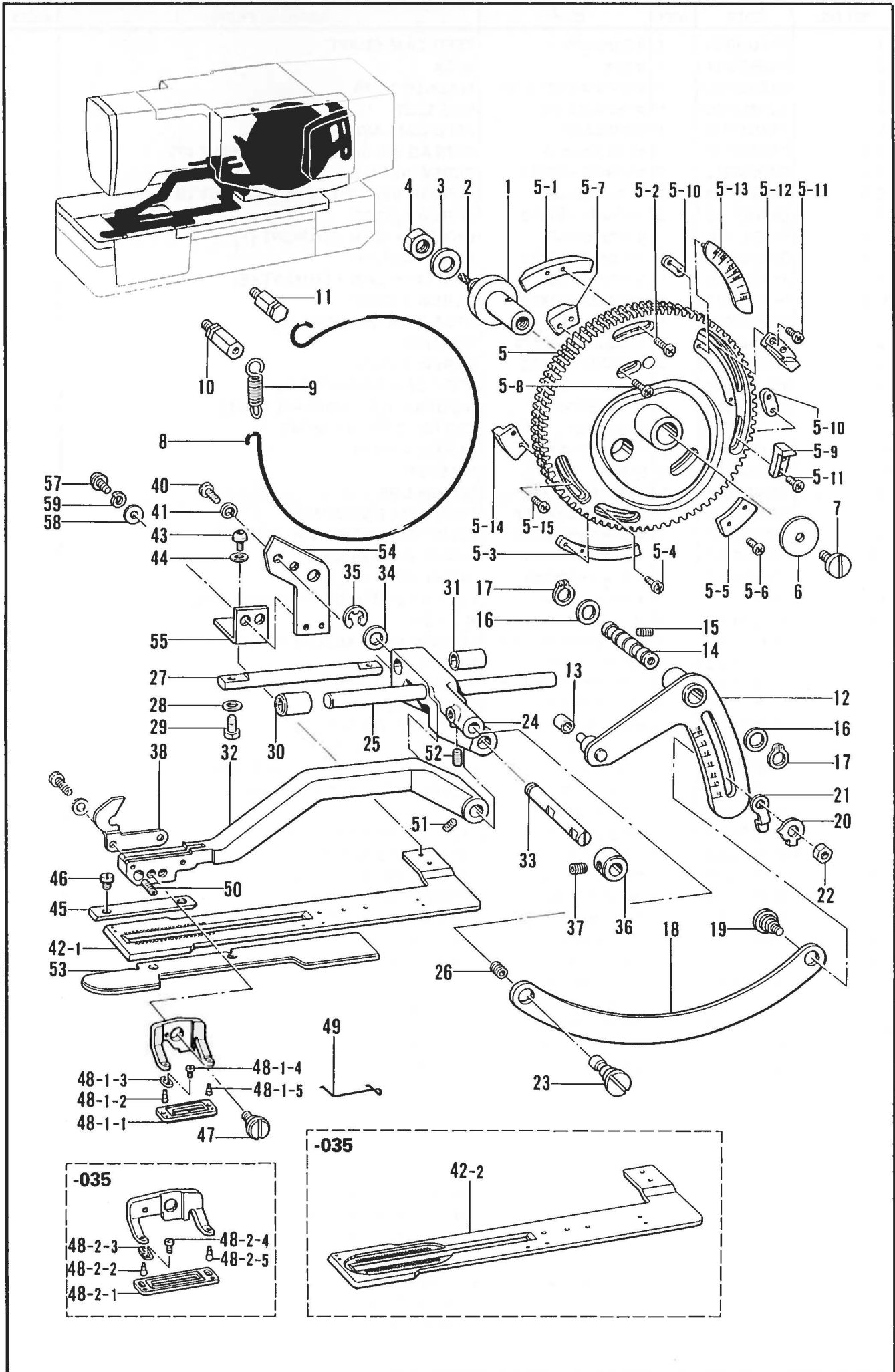

M. 送り関係 / Feed mechanism / Transportvorrichtung /
 Mécanisme de l'entraînement / Mecanismo de la alimentación

REF.NO.	CODE	Q'TY	ヒンメイ	NAME OF PARTS	RMKS
47	141439001	1	タ"ンネシ"6 35	STUD SCREW 6.35	
48-1	159765001	1	ヌ"ツカミ25RSクミ (-025)	UPPER CLAMPING FOOT ASSEMBLY (25RS) (-2) (-025)	
48-1-1	159762001	1	ヌ"ツカミ25RS	UPPER CLAMPING RUBBER FOOT (25RS)	
48-1-2	159926001	1	ヌ"ツカミササエピン L	CLAMPING FOOT SUPPORT PIN (LARGE)	
48-1-3	107401001	2	ヌ"ツカミササエイタハ"ネ	SPRING PLATE	
48-1-4	107404001	2	シメネシ"1.98	SCREW 1.98	
48-1-5	159927001	1	ヌ"ツカミササエピン S	CLAMPING FOOT SUPPORT PIN (SMALL)	
48-2	S01467001	1	ニツヨウヌ"ツカミ25クミ (-035)	UPPER CLAMPING FOOT ASSEMBLY (25MM) (FOR KNIT) (-035)	
48-2-1	144630001	1	ニツヨウヌ"ツカミ	UPPER CLAMPING RUBBER FOOT (25MM)	
48-2-2	159926001	1	ヌ"ツカミササエピン L	CLAMPING FOOT SUPPORT PIN (LARGE)	
48-2-3	144707001	2	ヌ"ツカミササエイタハ"ネ	SPRING PLATE	
48-2-4	107404001	2	シメネシ"1.98	SCREW 1.98	
48-2-5	159927001	1	ヌ"ツカミササエピン S	CLAMPING FOOT SUPPORT PIN (SMALL)	
49	159080000	1	-----	FINGER GUARD (MIDDLE)	
50	159078001	1	ヌ"ツカミササエハ"ネ	FOOT SUPPORTING SPRING	
51	014760622	1	ア"ナトメネシ"5.95	SCREW 5.95	
52	014760622	2	ア"ナトメネシ"5.95	SCREW 5.95	
53	S02975001	1	ハ"ツト"カハ"-R	BED COVER (RIGHT)	
54	S13649001	1	シ"タオク"リウテ"U	LOWER FEED ARM (U)	
55	S13650001	1	シ"タオク"リウテ"D	LOWER FEED ARM (D)	
57	153057002	2	オク"リイ"タシメネシ"	SCREW	
58	025680232	2	ヒ"ラサ"カ"ネ"チュウ4.37	WASHER 4.37	
59	028680242	2	ハ"ネ"サ"カ"ネ"2-4.37	SPRING WASHER 2-4.37	

N. カッター関係 / Cutter mechanism / Abschneidevorrichtung /
 Mécanisme de la coupe / Mecanismo de la corta

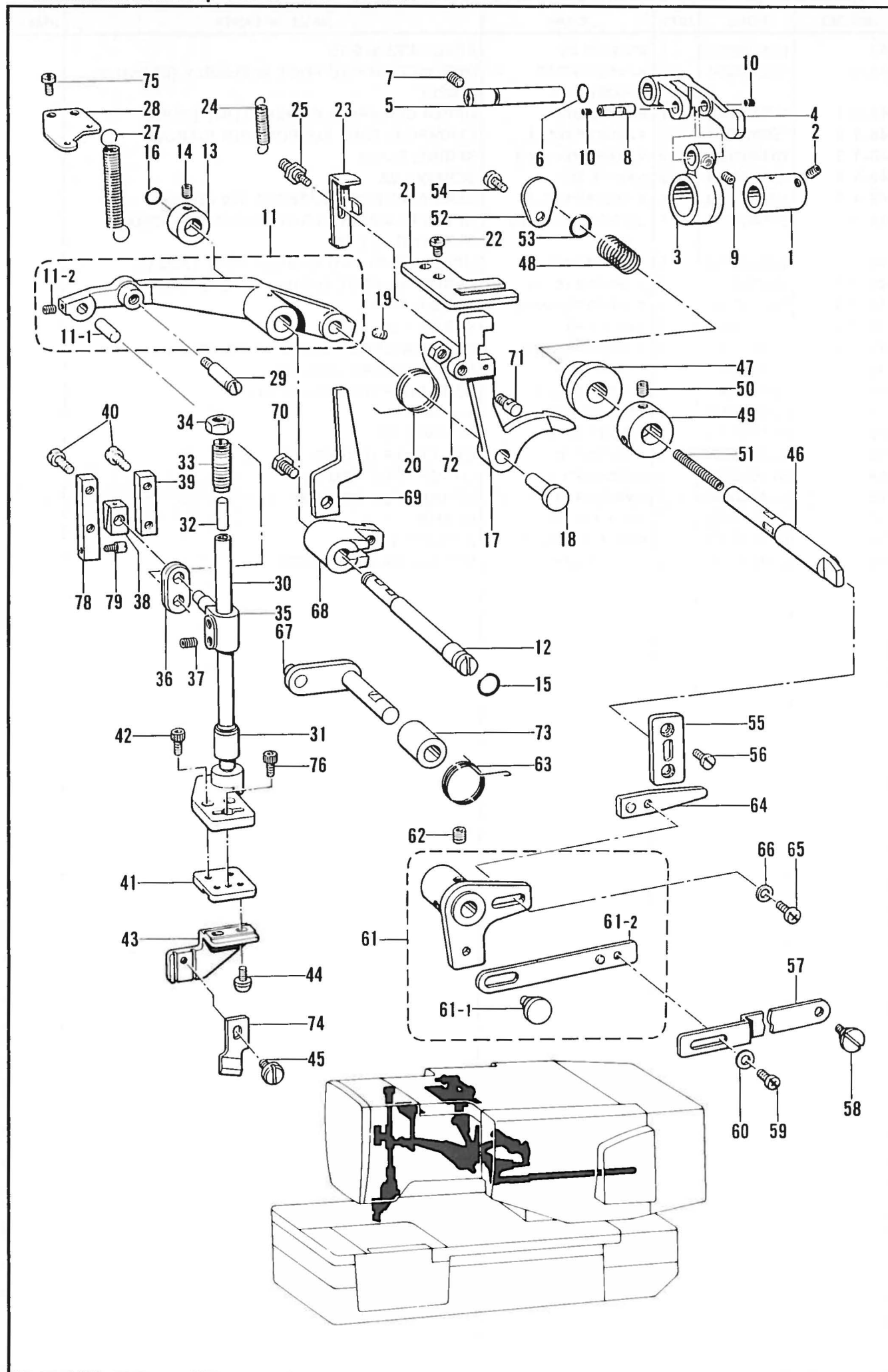

N. カッター関係/Cutter mechanism / Abschneidevorrichtung /
Mécánisme de la coupe / Mecanismo de la corta

REF. NO.	CODE	Q'TY	ヒンメイ	NAME OF PARTS	RMKS
1	159096001	1	カッタヘンシンリン	CUTTER ECCENTRIC WHEEL	
2	014770622	2	アナトメネシ"6.35クホ"ミ	SCREW 6.35	
3	159097001	1	カッタヘンシンリンロツト	CUTTER ECCENTRIC ROD	
4	159098001	1	カッタクト"ウレハ"ー	CUTTER DRIVING LEVER	
5	159099001	1	カッタクト"ウレハ"ーシ"ク	CUTTER DRIVING LEVER SHAFT	
6	081007070	1	Oリング"P7	O RING P7	
7	014760622	1	アナトメネシ"5.95	SCREW 5.95	
8	159100001	1	Cヘンシンリンロツトピン	CUTTER ECCENTRIC ROD PIN	
9	014680622	1	アナトメネシ"4.37クホ"ミ	SCREW 4.37	
10	159101000	2	メクラセン	OIL CAP	
11	159102001	1	カッタサト"ウウテ"クミ	CUTTER DRIVING ARM ASSEMBLY	
11-1	159104001	1	Cサト"ウウテ"ピン	PIN	
11-2	014680622	1	アナトメネシ"4.37クホ"ミ	SCREW 4.37	
12	159105001	1	カッタサト"ウウテ"シ"ク	CUTTER CONNECTING LEVER SHAFT	
13	159491001	1	セツトカラー	SET COLLAR	
14	014760622	2	アナトメネシ"5.95	SCREW 5.95	
15	081011070	1	Oリング"P11	O RING P11	
16	081006670	1	Oリング"PW6	O RING PW6	
17	159106001	1	Cクラッチ	CUTTER CLUTCH	
18	159107001	1	Cクラッチサト"ウピン	CUTTER CLUTCH DRIVING PIN	
19	014760622	1	アナトメネシ"5.95	SCREW 5.95	
20	159108001	1	カッタクラッチハ"ネ	CUTTER CLUTCH SPRING	
21	159109001	1	カッタクラッチアンナイ	CUTTER CLUTCH GUIDE	
22	062761212	2	ナヘ"コ595-28X12	SCREW 595X12	
23	159110001	1	Cクラッチアンナイイタ	CUTTER CLUTCH GUIDE PLATE	
24	159111001	1	Cクラッチアンナイハ"ネ	CUTTER CLUTCH GUIDE SPRING	
25	159112001	1	ハ"ネカケ	SPRING HOOK	
27	159114001	1	カッタモト"シハ"ネ	CUTTER RETURNING SPRING	
28	159115001	1	カッタモト"シハ"ネカケイタ	SPRING HOOK PLATE	
29	159395001	1	ハ"ネカケシ"ク	SPRING HOOK PIN	
30	159116001	1	カッタサト"ウシ"ク	CUTTER DRIVING SHAFT	
31	159117001	1	カッタサト"ウシ"クメタル	CUTTER DRIVING SHAFT BUSHING	
32	S01795000	1	カッタクツシヨ	CUTTER CUSHION	
33	159119101	1	チョウセツネシ"クミ	CUTTER STOPPER ADJUSTING SCREW ASSEMBLY	
34	021910302	1	ナツト3シユ12.70	NUT 12.70	
35	159120001	1	カッタサト"ウシ"クホルタ"ー	CUTTER DRIVING SHAFT HOLDER	
36	159329001	1	カッタサト"ウリンク	CUTTER DRIVING LINK	
37	014770622	2	アナトメネシ"6.35クホ"ミ	SCREW 6.35	
38	159570001	1	カッタアンナイカクコマ	CUTTER GUIDE BLOCK	
39	159121001	1	カッターホ"ウアンナイ	CUTTER BAR GUIDE	
40	062761212	4	ナヘ"コ595-28X12	SCREW 595X12	
41	159122001	1	カッタホルタ"ーU	CUTTER HOLDER (UPPER)	
42	018680822	2	アナホ"ルト4.37X8	BOLT 4.37X8	
43	159123001	1	カッタホルタ"ーD	CUTTER HOLDER (LOWER)	
44	153057002	2	オクリイタシメネシ"	FEED PLATE SCREW	
45	115503001	1	シメネシ"4.37	SCREW 4.37	
46	159124001	1	カッタオシホ"ウ	CUTTER CONNECTING SHAFT	
47	159126001	1	Cクラッチカラー	CUTTER CLUTCH COLLAR	
48	159127001	1	カラーオシハ"ネ	CUTTER CLUTCH COLLAR SPRING	
49	159128001	1	Cクラッチセツトカラー	CUTTER CLUTCH SET COLLAR	
50	014770622	2	アナトメネシ"6.35クホ"ミ	SCREW 6.35	
51	159129001	1	カッタクラッチホ"ウオシハ"ネ	CUTTER CLUTCH BAR SPRING	
52	159130001	1	ハ"ネアンナイササエ	SPRING GUIDE SUPPORTER	
53	081011070	1	Oリング"P11	O RING P11	
54	062710812	1	ナヘ"コ476-32X8	SCREW 476X8	
55	159131101	1	Cクラッチシ"クアンナイイタ	CUTTER CLUTCH SHAFT GUIDE PLATE	
56	107407003	2	シメネシ"4.37	SCREW 4.37	
57	159132001	1	カッタテイシレンカンL	CUTTER STOPPER LEVER CONNECTING PLATE L	
58	159908001	1	タ"ンネシ"4.37	STUD SCREW 4.37	
59	062680612	2	ナヘ"コ437-40X6	SCREW 437X6	
60	025680132	2	ヒラサ"カ"ネシヨウ4.37	WASHER 4.37	
61	158824001	1	カッタテイシレハ"ークミ	CUTTER STOP LEVER ASSEMBLY	

N: カッター関係 / Cutter mechanism / Abschneidevorrichtung /
 Mécanisme de la coupe / Mecanismo de la corta

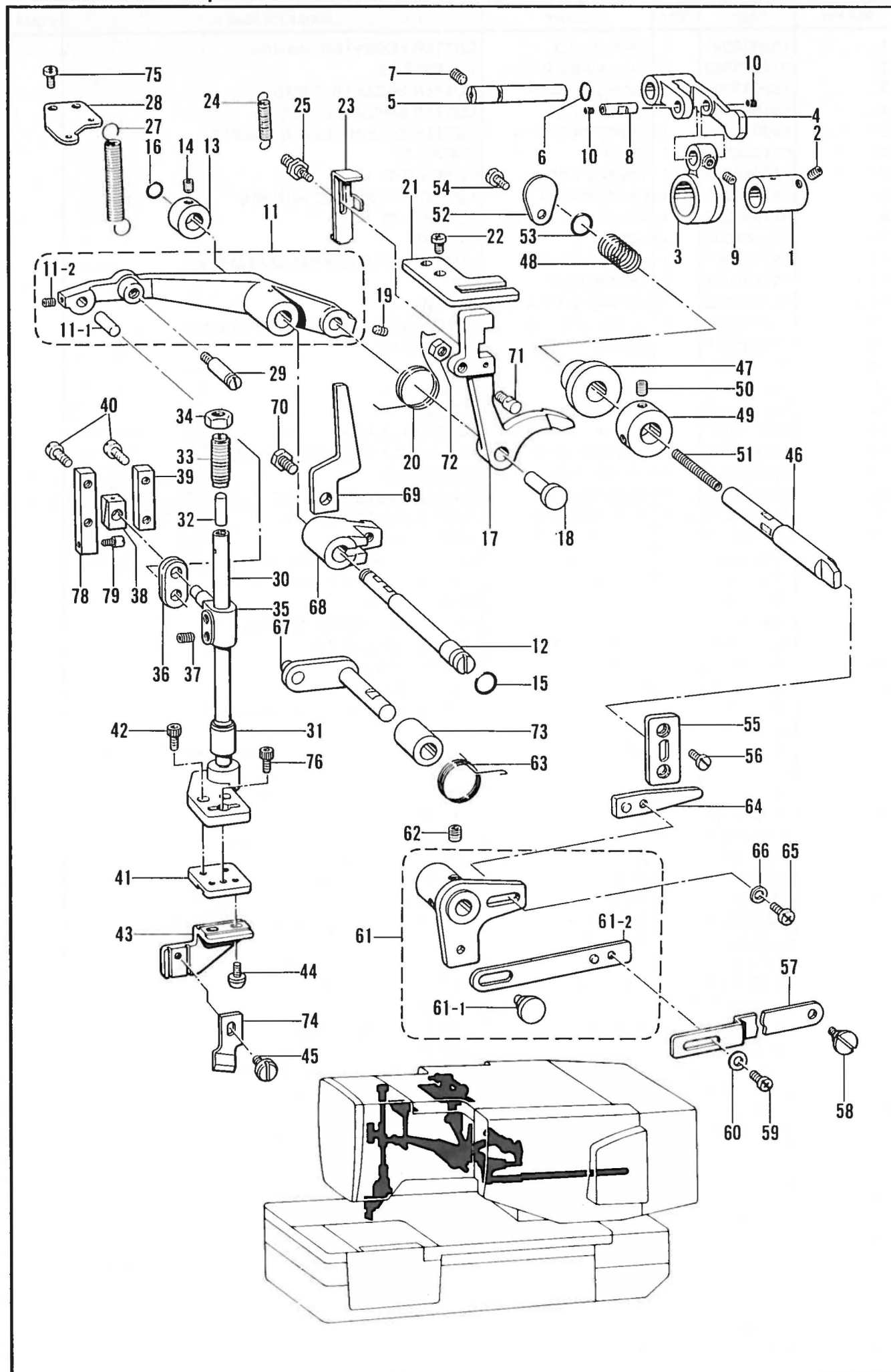

N. カッター関係 / Cutter mechanism / Abschneidevorrichtung /
Mécánisme de la coupe / Mecanismo de la corta

REF.NO.	CODE	Q'TY	ヒンメイ	NAME OF PARTS	RMKS
61-1	159133001	1	テイシレンカンカシメピン	STOPPER LEVER CONNECTING PLATE PIN	
61-2	158823001	1	カッタテイシレンカンS	CUTTER STOPPER CONNECTING PLATE (SMALL)	
62	014770622	2	アナトメネシ"6.35クホ"ミ	SCREW 6.35	
63	159135001	1	カッタテイシレハ"ーハ"ネ	CUTTER STOPPER LEVER SPRING	
64	159136001	1	カッタハス"シセツシヨクシ	CUTTER DETATCH LEVER	
65	062680612	2	ナヘ"コ437-40X6	SCREW 437X6	
66	025680132	2	ヒラサ"カ"ネシヨウ4.37	WASHER 4.37	
67	159137001	1	カッタテイシレハ"ーシ"ククミ	CUTTER STOPPER LEVER SHAFT ASSEMBLY	
68	159140001	1	Cテイシレハ"ーイタ"イ	CUTTER STOPPER LEVER BRACKET	
69	159141001	1	Cクラツチテイシレハ"ーイタ	CUTTER STOPPER LEVER PLATE	
70	017771412	1	ホル"ト6.35X14	BOLT 6.35X14	
71	159142101	1	カッタテイシピン	PIN	
72	150554002	1	ナツ"ト6.35	NUT 6.35	
73	159143000	1	アンセ"ンレハ"ーシ"クメタル	CUTTER DROP SAFETY LEVER SHAFT BUSHING	
74	107200001	1	カッタ1/2	CUTTER 1/2"	
75	062680812	2	ナヘ"コ437-40X8	SCREW 437X8	
76	018680522	1	アナホル"ト4.37X5	BOLT 4.37X5	
78	S02807001	1	カッターホ"ウアンナイフ	CUTTER BAR GUIDE (F)	
79	115120001	1	ハリカス"ヘンカンキ"ヤピン	STITCH CHANGING GEAR PIN	

P. 糸切れ感知関係 / Thread breakage detector mechanism / Fadenbruchfühler /
 Mécanisme du détecteur de cassure du fil / Mecanismo del sensor de cortes de hilo

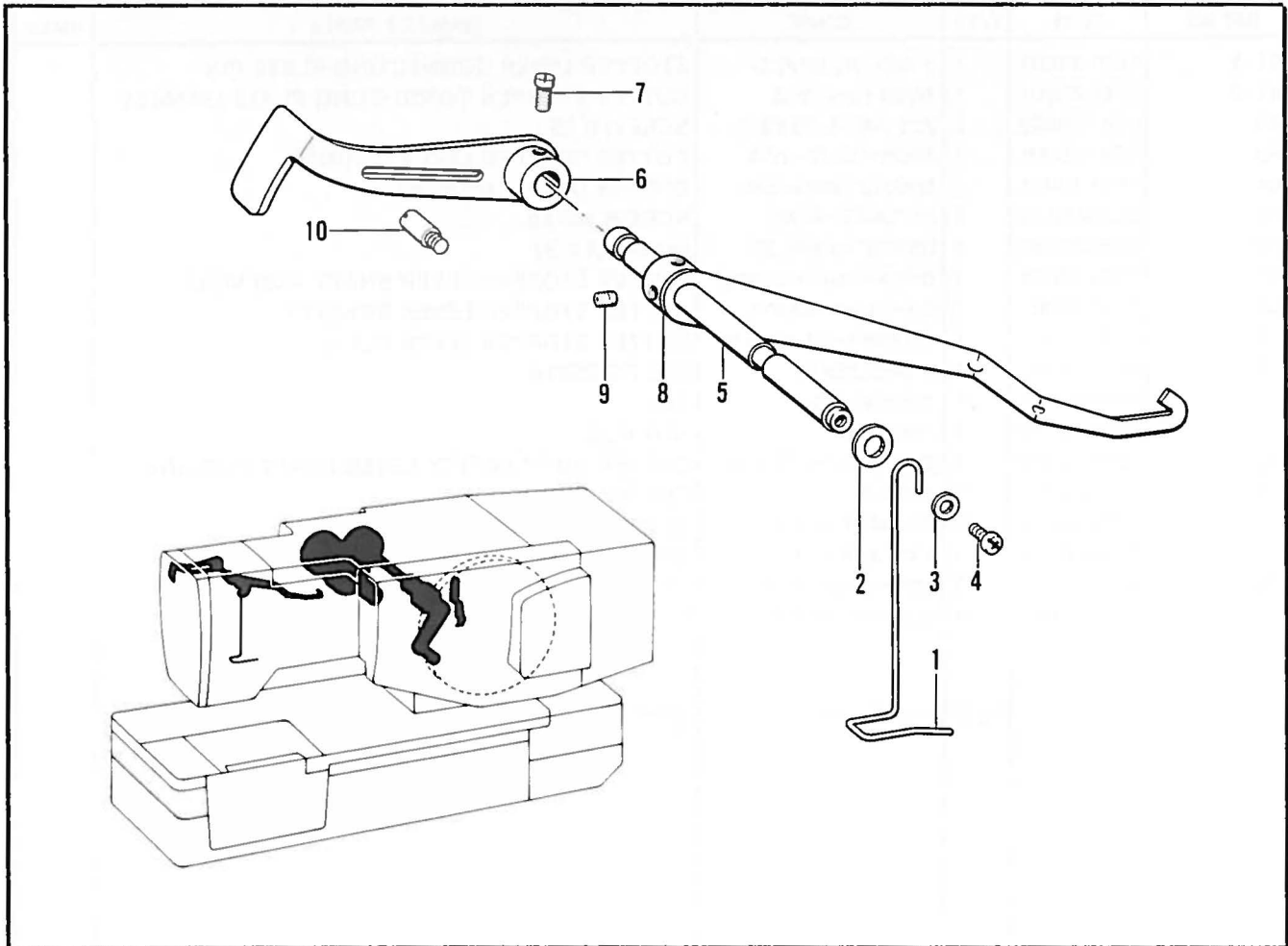

Q. 下軸関係 / Lower shaft mechanism / Untere Welle /
 Mécanisme de l'arbre inférieur / Mecanismo del eje inferior

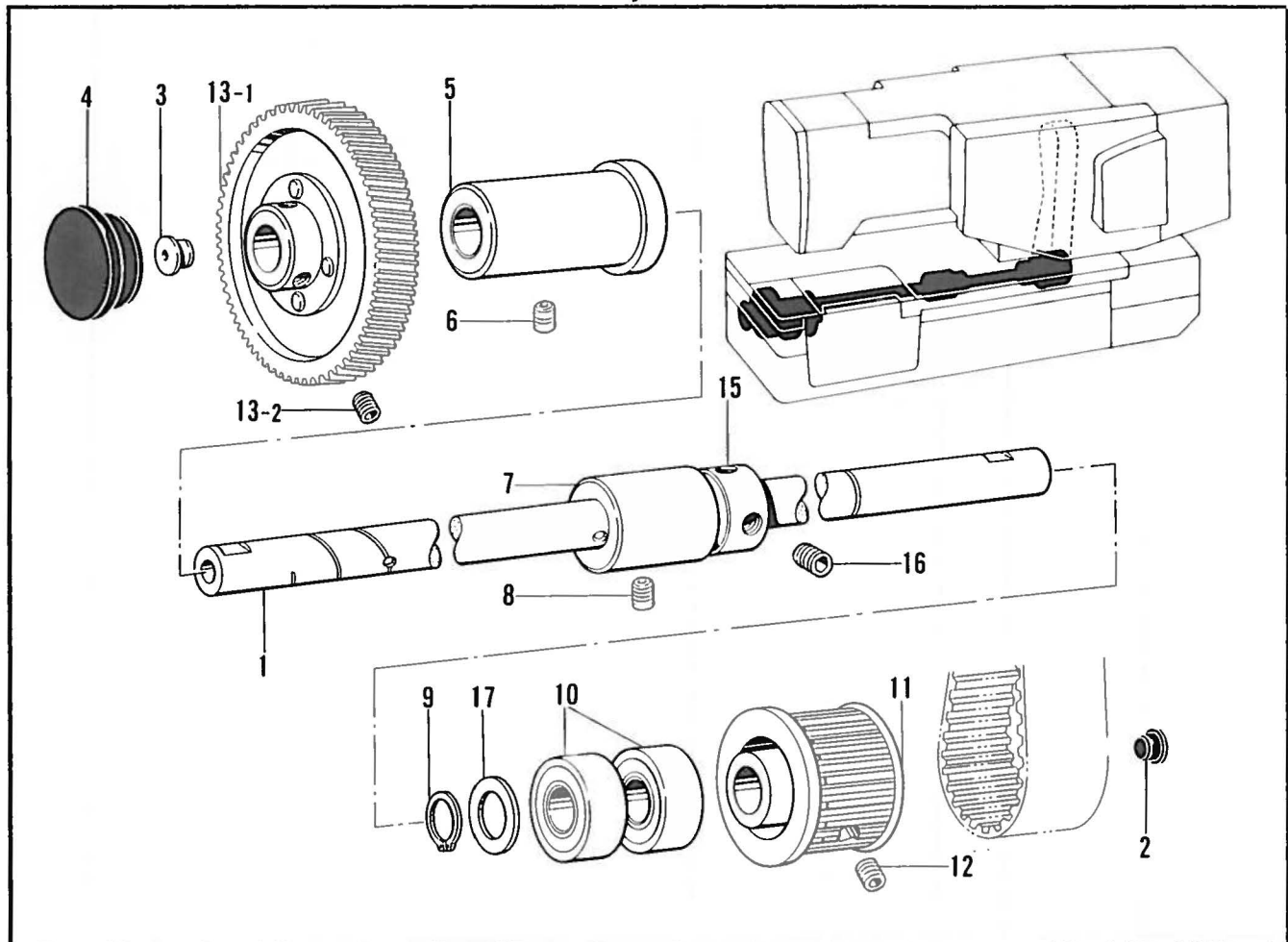

P. 糸切れ感知関係 / Thread breakage detector mechanism / Fadenbruchfühler /
 Mécanisme du détecteur de cassure du fil / Mecanismo del sensor de cortes de hilo

REF.NO.	CODE	Q'TY	ヒンメイ	NAME OF PARTS	RMKS
1	159144001	1	イトキレカンチイトアンナイ	THREAD BREAKAGE PERCEIVING WIRE	
2	025060232	1	ヒラサ"カ"ネチユウ6	WASHER 6	
3	025350332	1	ヒラサ"カ"ネタ"イ3.5	WASHER 3.5	
4	062670612	1	ナヘ"コ357-40X6	SCREW 357X6	
5	159145001	1	イトキレカンチレバ"ーシ"ク	THREAD BREAKAGE PERCEIVING LEVER SHAFT	
6	159146101	1	イトキレカンチレバ"ー	THREAD BREAKAGE PERCEIVING LEVER	
7	104908004	1	アタマツキトメネシ"4.37	SCREW 4.37	
8	159147001	1	カツタクラツチストツハ"	CUTTER CLUTCH STOPPER	
9	014680622	2	アナトメネシ"4.37クホ"ミ	SCREW 4.37	
10	159148001	1	カンチレバ"ーストツハ"	THREAD BREAKAGE PERCEIVING LEVER STOPPER	

Q. 下軸関係 / Lower shaft mechanism / Untere Welle /
 Mécanisme de l'arbre inférieur / Mecanismo del eje inferior

REF.NO.	CODE	Q'TY	ヒンメイ	NAME OF PARTS	RMKS
1	159162001	1	シタジ"ク	LOWER SHAFT	
2	104450101	1	メクラセン	OIL CAP	
3	114255002	1	キヤツフ"	CAP	
4	159163000	1	シタジ"クメクラセン	OIL CAP	
5	159164001	1	シタジ"クメタルF	LOWER SHAFT BUSHING (FRONT)	
6	014760622	1	アナトメネシ"5.95	SCREW 5.95	
7	158893000	1	ウワジ"クメタルM	UPPER SHAFT BUSHING (MIDDLE)	
8	014760622	1	アナトメネシ"5.95	SCREW 5.95	
9	048150142	1	トメワジ"クヨウC15	STOP RING C15	
10	072620200	2	タマシ"クウケ6202	BEARING 6202	
11	159745100	1	Dタイミンク"フ"ーリクミ	TIMING BELT WHEEL LOWER ASSEMBLY	
12	014760622	4	アナトメネシ"5.95	SCREW 5.95	
13	183710001	1	シタジ"クキ"ヤクミ	LOWER SHAFT GEAR ASSEMBLY	
13-1	159166001	1	シタジ"クキ"ヤクミ	LOWER SHAFT GEAR ASSEMBLY	
13-2	014770622	2	アナトメネシ"6.35クホ"ミ	SCREW 6.35	
15	159169001	1	シタジ"クセツトカラー	LOWER SHAFT SET COLLAR	
16	014770622	2	アナトメネシ"6.35クホ"ミ	SCREW 6.35	
17	116920001	1	オクリシ"クスラストリング"	THRUST RING	

R. カマ関係 / Rotary hook mechanism / Greifervorrichtung / Mécanisme du crochet rotatif / Mecanismo del cangrejo

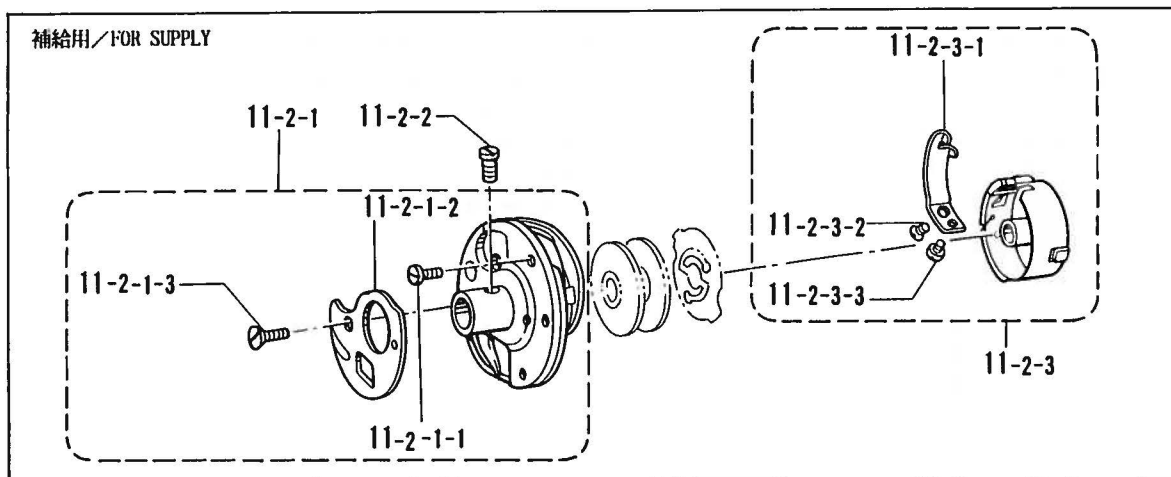
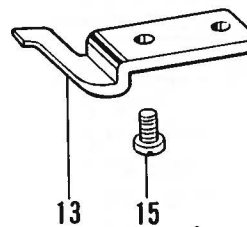
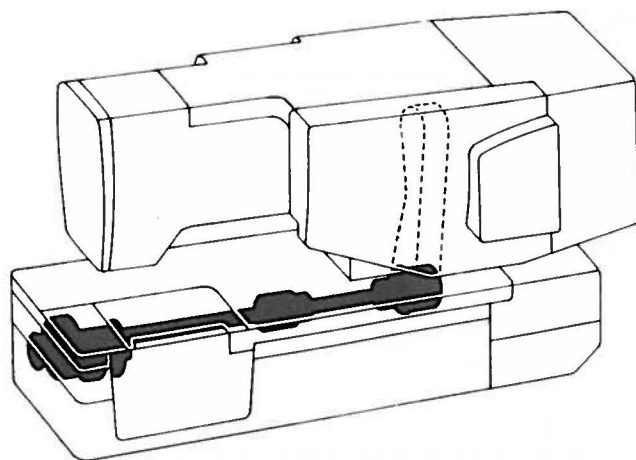
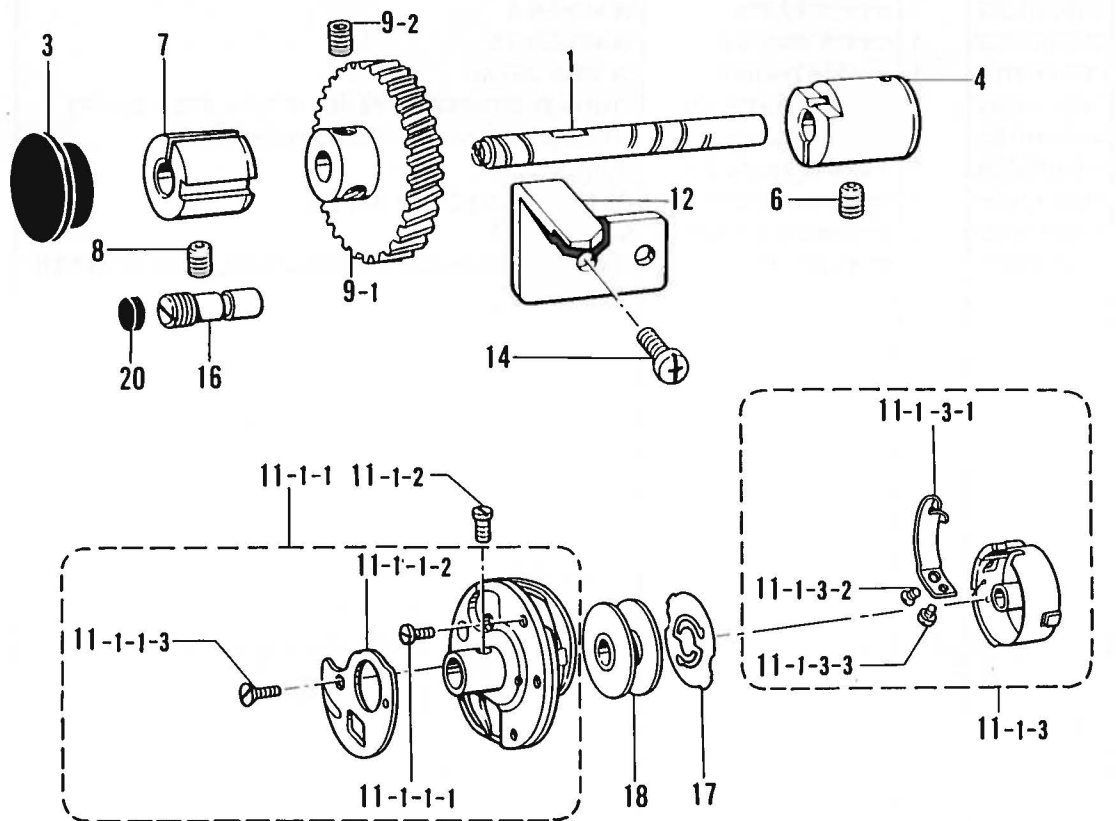

R. カマ関係 / Rotary hook mechanism / Greifervorrichtung /
Mécánisme du crochet rotatif / Mecanismo del cangrejo

REF.NO.	CODE	Q'TY	ヒンメイ	NAME OF PARTS	RMKS
1	S02972101	1	カマシ"ククミ	ROTARY HOOK SHAFT ASSEMBLY	
3	159150000	1	カマシ"クメクラセン	OIL CAP	
4	159151001	1	カマシ"クメタルR	ROTARY HOOK SHAFT BUSHING (REAR)	
6	014760622	1	アナトメネシ"5.95	SCREW 5.95	
7	159153201	1	カマシ"クメタルF	ROTARY HOOK SHAFT BUSHING (FRONT)	
8	014760622	1	アナトメネシ"5.95	SCREW 5.95	
9	183709001	1	カマシ"クキ"ヤクミ	ROTARY HOOK SHAFT GEAR ASSEMBLY	
9-1	159154001	1	カマシ"クキ"ヤ	ROTARY HOOK SHAFT GEAR	
9-2	014770622	2	アナトメネシ"6.35クホ"ミ	SCREW 6.35	
11-1	159155101	1	カマホ"ヒ"ンケースクミ	ROTARY HOOK BOBBIN CASE ASSEMBLY	
11-1-1	159156201	1	カマクミ	ROTARY HOOK ASSEMBLY	
11-1-1-1	183508001	3	ナカカマオサエシメネシ"	SCREW	
11-1-1-2	183596001	1	カマウライタ	ROTARY HOOK REAR PLATE	
11-1-1-3	183598001	1	ウライタシメネシ"	SCREW	
11-1-2	183490001	2	B815ソトカマトメネシ"	SETTING SCREW FOR ROTARY HOOK (B815)	
11-1-3	159157001	1	ホ"ヒ"ンケースクミ	BOBBIN CASE ASSEMBLY	
11-1-3-1	S09477001	1	ホ"ヒ"ンチヨウシハ"ネ	BOBBIN ADJUSTING SPRING	
11-1-3-2	180721001	1	チヨウシハ"ネシメネシ"	ADJUSTING SPRING SCREW	
11-1-3-3	183507001	1	チヨウシネシ"	ADJUSTING SCREW	
11-2	S11453101	1	カマホ"ヒ"ンケースクミ <ホキユウヨウ>	ROTARY HOOK BOBIN CASE ASSEMBLY <FOR SUPPLY>	
11-2-1	S11454201	1	カマクミ	ROTARY HOOK ASSEMBLY	
11-2-1-1	183526001	3	ナカカマオサエシメネシ"	SCREW	
11-2-1-2	183596001	1	カマウライタ	ROTARY HOOK REAR PLATE	
11-2-1-3	183598001	1	ウライタシメネシ"	SCREW	
11-2-2	183490001	2	B815ソトカマトメネシ"	SETTING SCREW FOR ROTARY HOOK (B815)	
11-2-3	159157001	1	ホ"ヒ"ンケースクミ	BOBBIN CASE ASSEMBLY	
11-2-3-1	S09477001	1	ホ"ヒ"ンチヨウシハ"ネ	BOBBIN ADJUSTING SPRING	
11-2-3-2	180721001	1	チヨウシハ"ネシメネシ"	ADJUSTING SPRING SCREW	
11-2-3-3	183507001	1	チヨウシネシ"	ADJUSTING SCREW	
12	159159001	1	カマトメA	ROTARY HOOK HOLDER (A)	
13	159160001	1	カマトメB	ROTARY HOOK HOLDER (B)	
14	062711012	2	ナヘ"コ476-32X10	SCREW 476X10	
15	062680612	2	ナヘ"コ437-40X6	SCREW 437X6	
16	159161001	1	カマキユウチヨウセツネシ"	HOOK OIL SUPPLY ADJUSTING SCREW	
17	S01109001	1	ホ"ヒ"ンオサエハ"ネ <ホキユウヨウ>	SPRING <FOR SUPPLY>	
18	159158001	1	ホ"ヒ"ン	BOBBIN	
20	S14154001	1	コ"ムセン	OIL CAP	

S. 給油潤滑關係 / Lubrication / Schmierung /
Lubrification / Lubricación

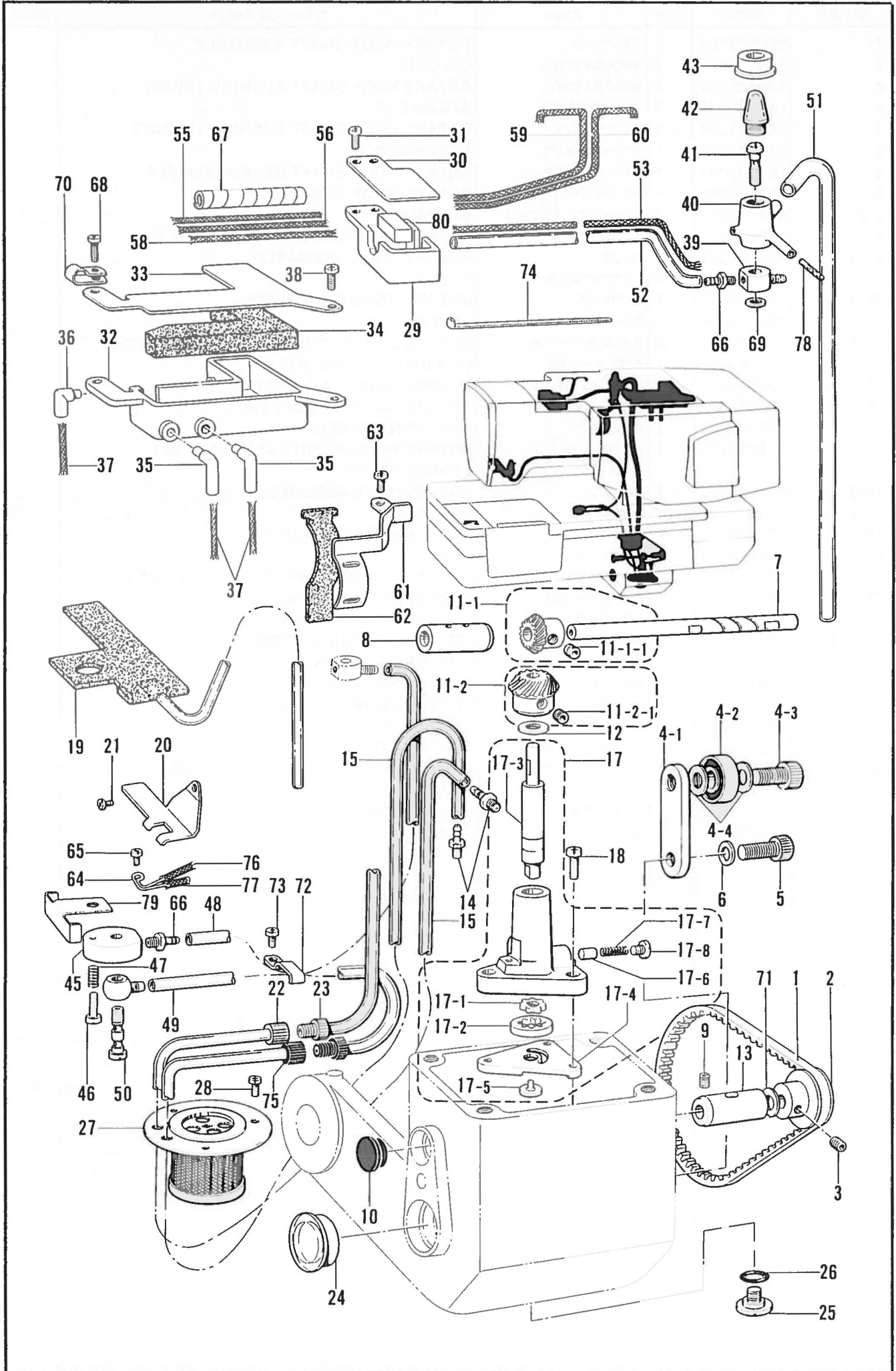

S. 給油潤滑関係 / Lubrication / Schmierung /
Lubrification / Lubricación

REF.NO.	CODE	Q'TY	ヒンメイ	NAME OF PARTS	RMKS
1	159170000	1	ポンプベルト	PUMP BELT	
2	159171000	1	ポンププーリーTR	PUMP PULLEY	
3	014760622	2	アタメネジ5.95	SCREW 5.95	
4	159172001	1	Pテンションプーリークミ	PUMP BELT TENSION PULLEY ASSEMBLY	
4-1	159173001	1	Pテンションプーリークミ	PUMP BELT TENSION PULLEY ASSEMBLY	
4-2	072600040	1	タマシクウケ6000DD	BEARING 6000DD	
4-3	018101622	1	アナボルト 10X16	BOLT 10X16	
4-4	025100132	1	ヒラサカネシヨウ10	WASHER 10	
5	018081422	1	アナボルト8X14	BOLT 8X14	
6	025080232	1	ヒラサカネチユウ8	WASHER 8	
7	159174001	1	ポンププーリーシク	PUMP PULLEY SHAFT	
8	142766001	1	ポンププーリーシクメタル	PUMP PULLEY SHAFT BUSHING	
9	014760622	1	アタメネジ5.95	SCREW 5.95	
10	150756000	1	メクラセン	OIL CAP	
11-1	143915001	1	ヘルキヤDクミ	PUMP SHAFT GEAR (D) ASSEMBLY	
11-1-1	014770622	2	アタメネジ6.35クホミ	SCREW 6.35	
11-2	180515001	1	ヘルキヤDクミ	LOWER SHAFT GEAR (D) ASSEMBLY	
11-2-1	014770622	2	アタメネジ6.35クホミ	SCREW 6.35	
12	110367001	1	サカネ	WASHER	
13	S01047001	1	ポンプメタルF	BUSHING (FRONT)	
14	142359001	2	オイルクチ	OIL FEEDING	
15	159175000	2	ビニルチューブ	VINYL TUBE	
17	148761001	1	ポンプクミ	PUMP ASSEMBLY	
17-1	141643000	1	オイルポンプインナーロータ	OIL PUMP INNER ROTOR	
17-2	141642000	1	オイルポンプアウターロータ	OIL PUMP OUTER ROTOR	
17-3	148469001	1	ポンプシク	PUMP SHAFT	
17-4	148470001	1	ポンプフタ	PUMP CAP PLATE	
17-5	145465001	1	シメネジ3.57L	SCREW 3.57 (L)	
17-6	148471001	1	プランジヤ	PLUNGER	
17-7	144876001	1	プランジヤハネ	PLUNGER SPRING	
17-8	112467002	1	シメネジ6.35	SCREW 6.35	
18	062711212	3	ナヘコ476-32X12	SCREW 476X12	
19	159178101	1	スイアケチューブクミ	ABSORBING TUBE ASSEMBLY	
20	159181001	1	スイアケフェルトササエ	FELT HOLDER	
21	062670612	1	ナヘコ357-40X6	SCREW 357X6	
22	142750002	1	ツキテナツト	NUT	
23	142748002	1	ビニルチューブツキテ	OIL FEEDING PIPE	
24	152948001	1	オイルホツトマ	OIL GAUGE WINDOW	
25	110641002	1	タメネジ9.52	STUD SCREW 9.52	
26	109203001	1	Oリング	O RING	
27	159182101	1	フィルタークミ	OIL FELTAR ASSEMBLY	
28	062680812	3	ナヘコ437-40X8	SCREW 437X8	
29	159187000	1	トウシンベースA	FELT BASE (A)	
30	159188001	1	トウシンベースAフタ	WICK BASE (A) CAP	
31	062680812	2	ナヘコ437-40X8	SCREW 437X8	
32	159189000	1	トウシンベースB	FELT BASE (B)	
33	159190001	1	トウシンベースBフタ	WICK BASE (B) CAP	
34	159191000	1	トウシンベースBフェルト	FELT	
35	159192000	2	オイルパイプA	OIL PIPE (A)	
36	159193000	1	オイルパイプB	OIL PIPE (B)	
37	159601000	3	クミヒモ4X4	WICK 4X4	
38	062680812	1	ナヘコ437-40X8	SCREW 437X8	
39	159194000	1	キユウクチ	VINYL TUBE JOINT	
40	159195000	1	オイルターミナル	OIL TERMINAL	
41	159199001	1	オイルフキタシクチ	OIL FLOWING SCREW	
42	143713001	1	オイルキヤツプ	OIL GAUGE WINDOW	
43	159201000	1	アブラマトササエ	OIL WINDOW HOLDER	
45	159203100	1	キユウユチヨウセツタイ	OIL ADJUSTING BASE	
46	062681412	1	ナヘコ437-40X14	SCREW 437X14	
47	159204001	1	チヨウセツネジハネ	OIL SUPPLY ADJUSTING SCREW SPRING	
48	159205101	1	キユウユチチューブクミA	VINYL TUBE ASSEMBLY (A)	
49	159207101	1	キユウユチチューブクミB	VINYL TUBE ASSEMBLY (B)	

S. 給油潤滑關係 / Lubrication / Schmierung /
Lubrification / Lubricación

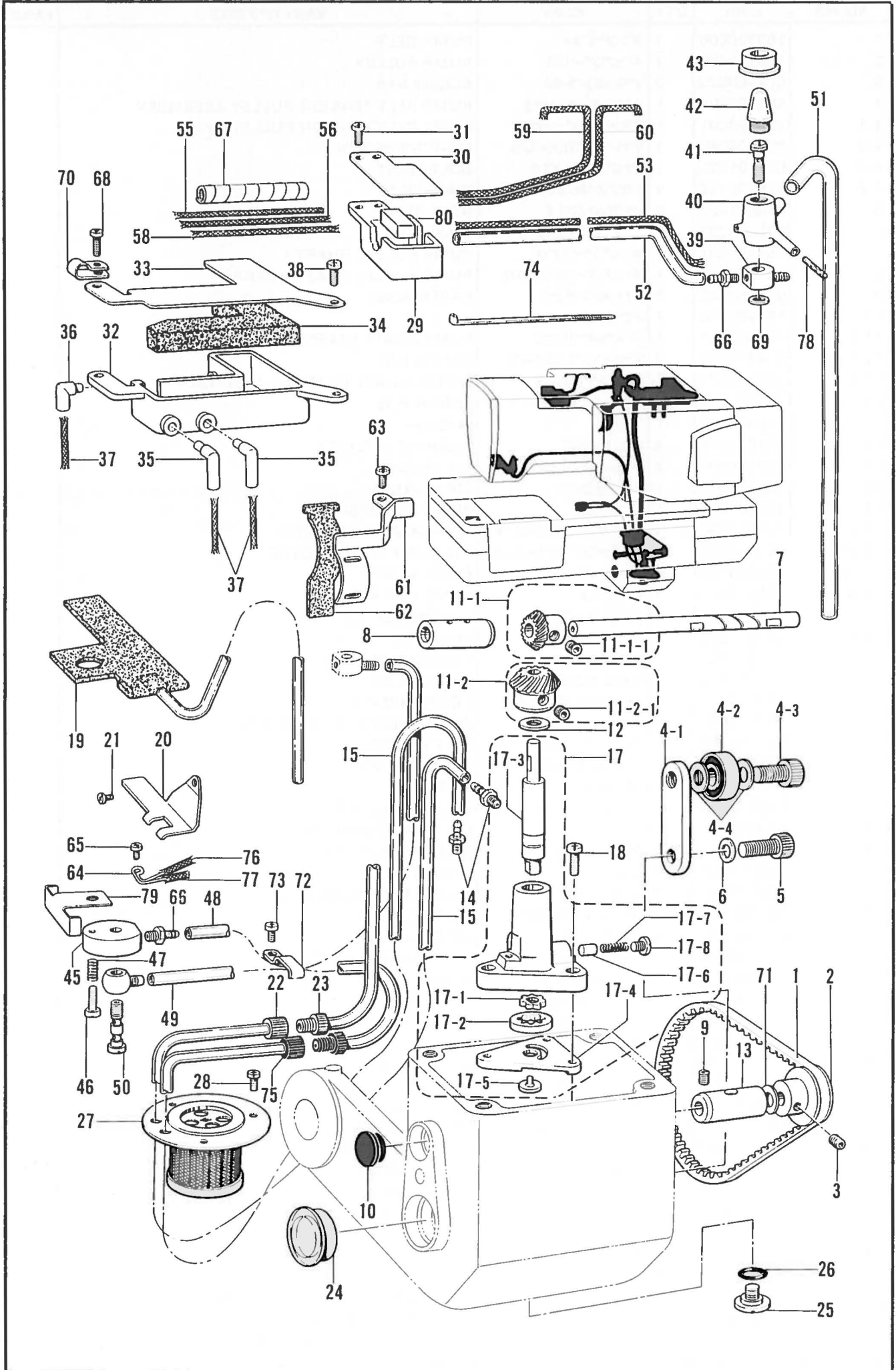

S. 給油潤滑関係 / Lubrication / Schmierung /
Lubrification / Lubricación

REF. NO.	CODE	Q'TY	ヒンメイ	NAME OF PARTS	RMKS
50	112364001	1	ハイユパイフツキ"テネシ"	OIL FEEDING PIPE JOINT SCREW	
51	159209000	1	ビ"ニルチューブ"	VINYL TUBE	
52	141650000	1	ビ"ニルチューブ"	VINYL TUBE	
53	159564000	1	クミヒモ2.5X500	WICK 2.5X500	
55	159565000	1	クミヒモ2.5X150	WICK 2.5X150	
56	159566000	1	クミヒモ3X450	WICK 3X450	
58	159567000	1	クミヒモ3X180	WICK 3X180	
59	159568000	1	クミヒモ2.5X100	WICK 2.5X100	
60	159569000	1	クミヒモ2.5X150	WICK 2.5X150	
61	159213001	1	ウオームフェルトササエ	WORM FELT HOLDER	
62	159214000	1	ウオームフェルト	WORM FELT	
63	062680612	2	ナヘ"コ437-40X6	SCREW 437X6	
64	159215001	1	カマキユウエアンナイ	ROTARY HOOK OIL GUIDE	
65	062670512	1	ナヘ"コ357-40X5	SCREW 357X5	
66	142359001	2	オイルクチ	OIL FEEDING	
67	159909000	1	スパイラルチューブ"	SPIRAL TUBE	
68	062681012	1	ナヘ"コ437-40X10	SCREW 437X10	
69	112348001	1	パツキン	PACKING	
70	149547000	1	コート"オサエ	CORD HOLDER (4N)	
71	107153001	1	サ"カ"ネ	WASHER	
72	142268001	1	コート"オサエL	CORD HOLDER (L)	
73	062670612	1	ナヘ"コ357-40X6	SCREW 357X6	
74	149799000	2	タイラツプ"S	BEAD BAND (S)	
75	142750001	1	ツキ"テナット	JOINT NUT	
76	S03238000	1	リリアンクミヒモ21	WICK 21	
77	S03239000	1	リリアンクミヒモ18	WICK 18	
78	106436001	1	フェルト	OIL FELT	
79	S09566001	1	オイルカバー	OIL COVER	
80	S17063000	1	トウシンハ"ースクツシヨ	CUSHION	

T. 糸通シ関係/Threading mechanism / FadenführungsVorrichtung /
 Mécanisme de l'enfilage / Mecanismo del enhebrado

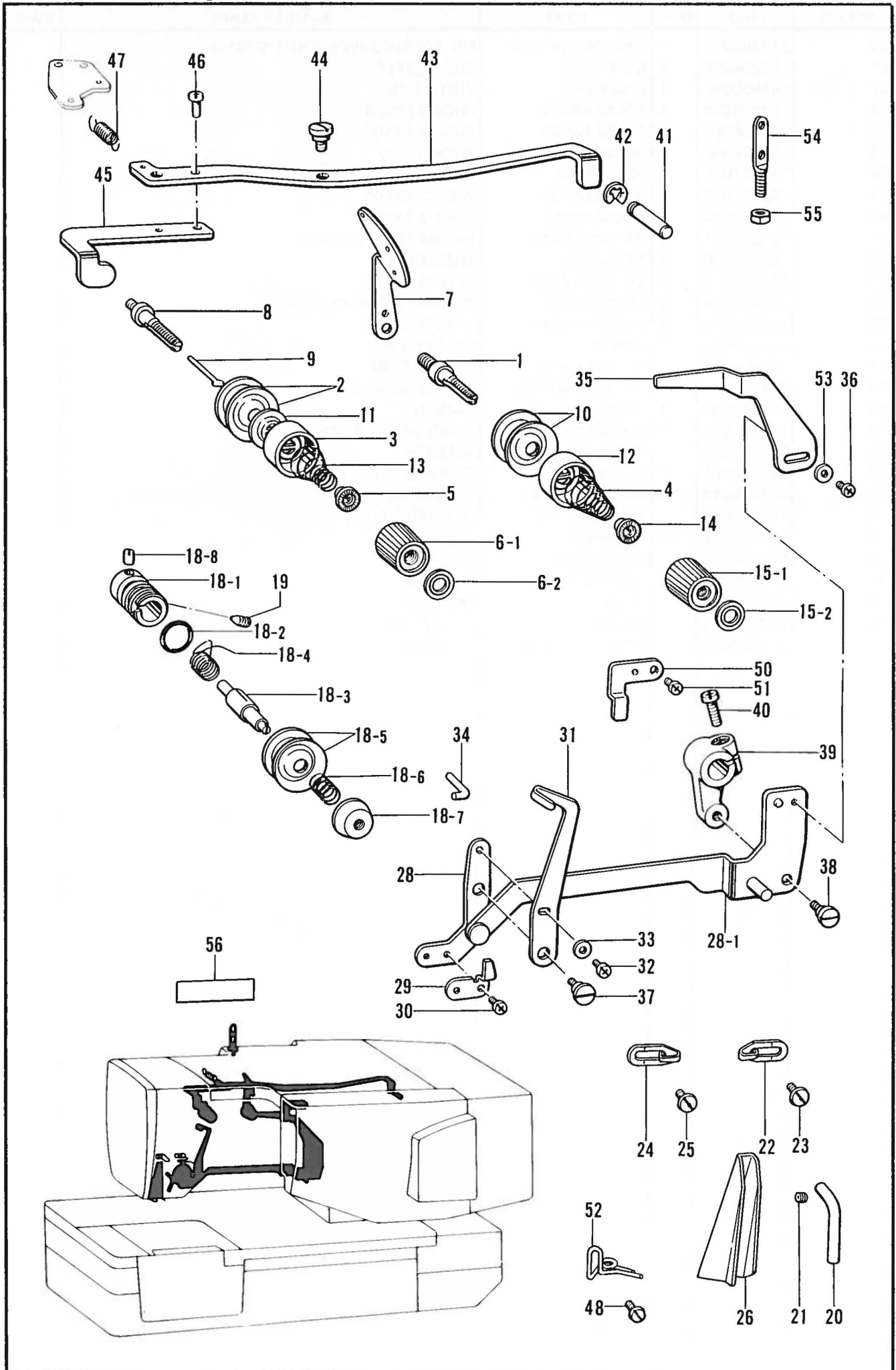

T. 糸通シ関係 / Threading mechanism / Fadenführungsrichtung /
Mécánisme de lénfilage / Mecanismo del enhebrado

REF.NO.	CODE	Q'TY	ヒンメイ	NAME OF PARTS	RMKS
1	110820101	1	イトチヨウシホ"ウ	TENSION CONTROL STUD	
2	145446001	2	イトチヨウシサラ	TENSION DISC	
3	144103003	1	イトチヨウシサラオサエ	TENSION DISC WASHER	
4	144104001	1	ハリイトチヨウシハ"ネ	TENSION SPRING	
5	144105000	1	チヨウシハ"ネウエサ"カ"ネ	TENSION SPRING WASHER	
6	155696003	1	イトチヨウシナツクミ(アカ)	THREAD TENSION CONTROL NUT ASSEMBLY(RED)	
6-1	149566002	1	イトチヨウシナツト	THREAD TENSION CONTROL NUT	
6-2	155697003	1	キョウシ"ヤクハ"ン	TENSION INDICATING PLAIE	
7	159218001	1	ミツメイトカケ	THREAD RETAINER	
8	159219101	1	フクイトチヨウシホ"ウ	SUB TENSION STUD	
9	159220101	1	イトユルメヒ"ン	TENSION RELEASE PIN	
10	145446001	2	イトチヨウシサラ	TENSION DISC	
11	159805001	1	イトチヨウシサラオサエ	TENSION DISC PRESSER	
12	144103003	1	イトチヨウシサラオサエ	TENSION DISC PRESSER	
13	159221001	1	イトチヨウシハ"ネ	TENSION SPRING	
14	144105000	1	チヨウシハ"ネウエサ"カ"ネ	TENSION SPRING WASHER	
15	155696002	1	イトチヨウシナツクミ (ミト"リ)	THREAD TENSION CONTROL NUT ASSEMBLY (GREEN)	
15-1	149566002	1	イトチヨウシナツト	THREAD TENSION CONTROL NUT	
15-2	155697002	1	キョウシ"ヤクハ"ン	TENSION INDICATING PLAIE	
18	159623001	1	イトチヨウシタ"イクミ	TENSION REGULATOR BRACKET ASSEMBLY	
18-1	144741001	1	イトチヨウシホ"ウタ"イ	THREAD TENSION REGULATOR BRACKET	
18-2	114294001	1	Oリング"	O RING	
18-3	159222001	1	イトトリハ"ネチヨウセツホ"ウ	TENSION STUD	
18-4	145519001	1	イトトリハ"ネ	THREAD TAKE-UP SPRING	
18-5	145446001	2	イトチヨウシサラ	TENSION DISC	
18-6	159223001	1	サブ"イトチヨウシハ"ネ	SUB TENSION SPRING	
18-7	159331001	1	イトチヨウシサラナツト	TENSION CONTROL NUT	
18-8	100402004	1	トメネシ"3.57	SCREW 3.57	
19	103950003	1	トメネシ"5.95	SCREW 5.95	
20	159224001	1	アームイトカケ	ARM THREAD GUIDE	
21	014680622	1	アナトメネシ"4.37クホ"ミ	SCREW 4.37	
22	113316001	1	アームイトアンナイ	ARM THREAD GUIDE	
23	112751002	1	シメネシ"3.57	SCREW 3.57	
24	113316001	1	アームイトアンナイ	ARM THREAD GUIDE	
25	112751002	1	シメネシ"3.57	SCREW 3.57	
26	159546101	1	イトオシイタ	THREAD GUIDE	
28	159228001	1	イトトリレハ"ークミ	THREAD TAKE-UP LEVER ASSEMBLY	
28-1	159229001	1	イトトリレハ"ー	THREAD TAKE-UP LEVER	
29	159234001	1	チヨウシサラワリツメ	TENSION DISC OPENNING CLAW	
30	062670512	2	ナヘ"コ357-40X5	SCREW 357X5	
31	159235101	1	ウワイトユルメ	UPPER THREAD RELEASE LEVER	
32	062680512	1	ナヘ"コ437-40X5	SCREW 437X5	
33	025680132	1	ヒラサ"カ"ネシヨウ4.37	WASHER 4.37	
34	159236001	1	イトトリヒ"ン	THREAD TAKE-UP PIN	
35	159237001	1	シユチヨウシユルメイタ	TENSION RELEASE PLATE	
36	062680612	1	ナヘ"コ437-40X6	SCREW 437X6	
37	159238001	1	タ"ンネシ"4.37	STUD SCREW 4.37	
38	159908001	1	タ"ンネシ"4.37	STUD SCREW 4.37	
39	159239001	1	イトトリレハ"ーウテ"	THREAD TAKE-UP LEVER ARM	
40	062761612	1	ナヘ"コ595-28X16	SCREW 5.95X16	
41	159240001	1	イトユルメサト"ウヒ"ン	TENSION RELEASE DRIVING PIN	
42	048040342	1	トメフE4	STOP RING E4	
43	159241001	1	イトユルメテコ	TENSION RELEASE LEVER	
44	144526001	1	タ"ンネシ"4.37	STUD SCREW 4.37	
45	159242001	1	イトユルメテ"CS	TENSION RELEASE LEVER (S)	
46	062680812	2	ナヘ"コ437-40X8	SCREW 437X8	
47	159243001	1	イトユルメテコハ"ネ	TENSION RELEASE LEVER SPRING	
48	112751002	1	シメネシ"3.57	SCREW 3.57	
50	159226001	1	シユチヨウシユルメアンナイ	TENSION RELEASE GUIDE	
51	062680612	1	ナヘ"コ437-40X6	SCREW 437X6	
52	159917101	1	アームイトアンナイシタ	ARM THREAD GUIDE	

T. 糸通シ関係 / Threading mechanism / FadenführungsVorrichtung /
 Mécanisme de l'enfilage / Mecanismo de la enhebrado

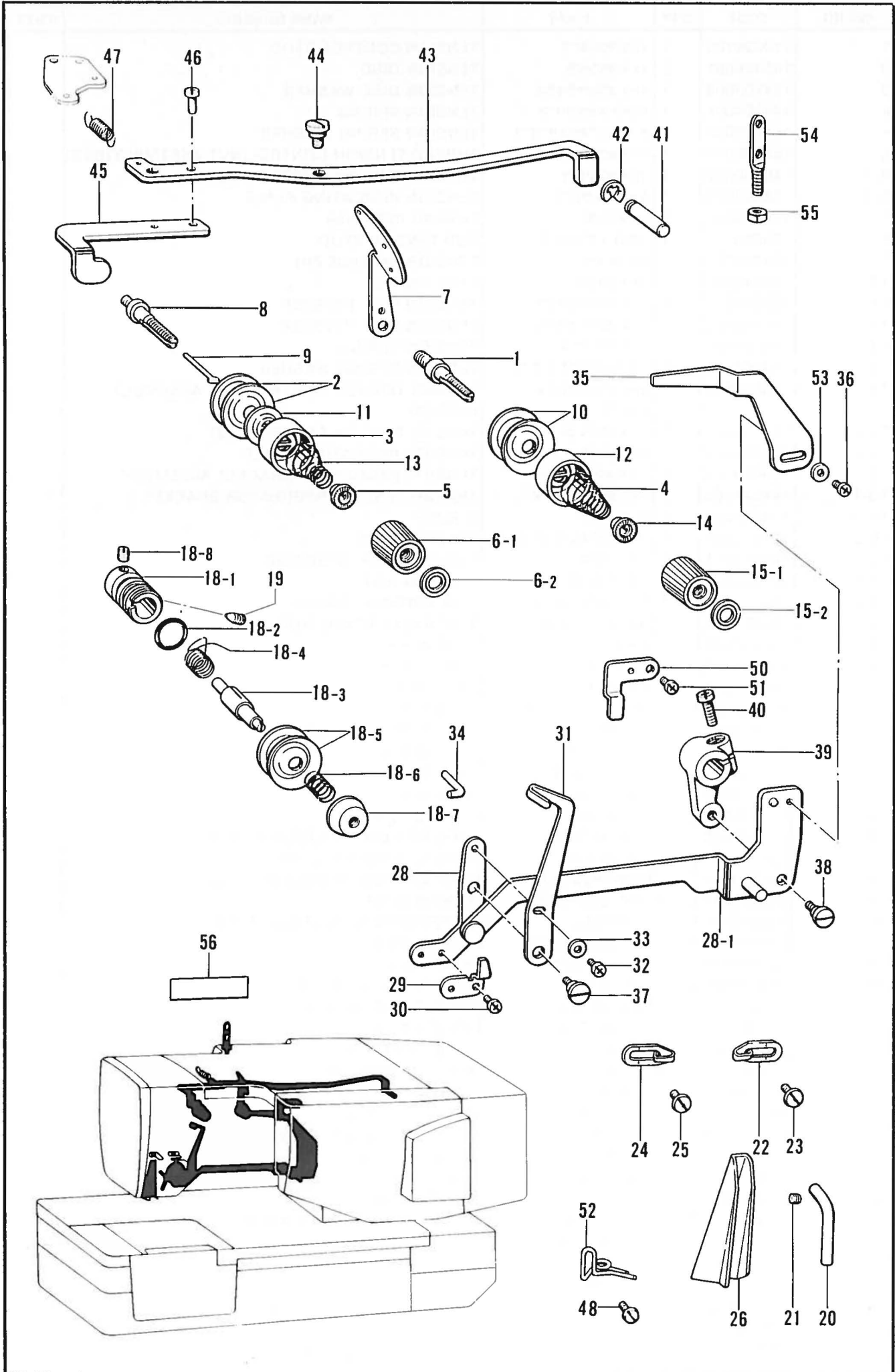

T. 糸通シ関係 / Threading mechanism / Fadenführungsrichtung /
 Mécanisme de l'enfilage / Mecanismo de la enhebrado

REF.NO.	CODE	Q'TY	ヒンメイ	NAME OF PARTS	RMKS
53	025680132	1	ヒラサ"カ"ネシヨウ4.37	WASHER 4.37	
54	141590001	1	イトオシホ"ウ	THREAD RETAINER (UPPER)	
55	150553003	1	ナツト5.95	NUT 5.95	
56	S13713001	1	チヨウシツマミセツメイイタ	DIAGRAM	

U. 糸巻装置 / Bobbin winder / Spuler /
 Mécanisme du bobineur / Mecanismo del devanador de la canilla

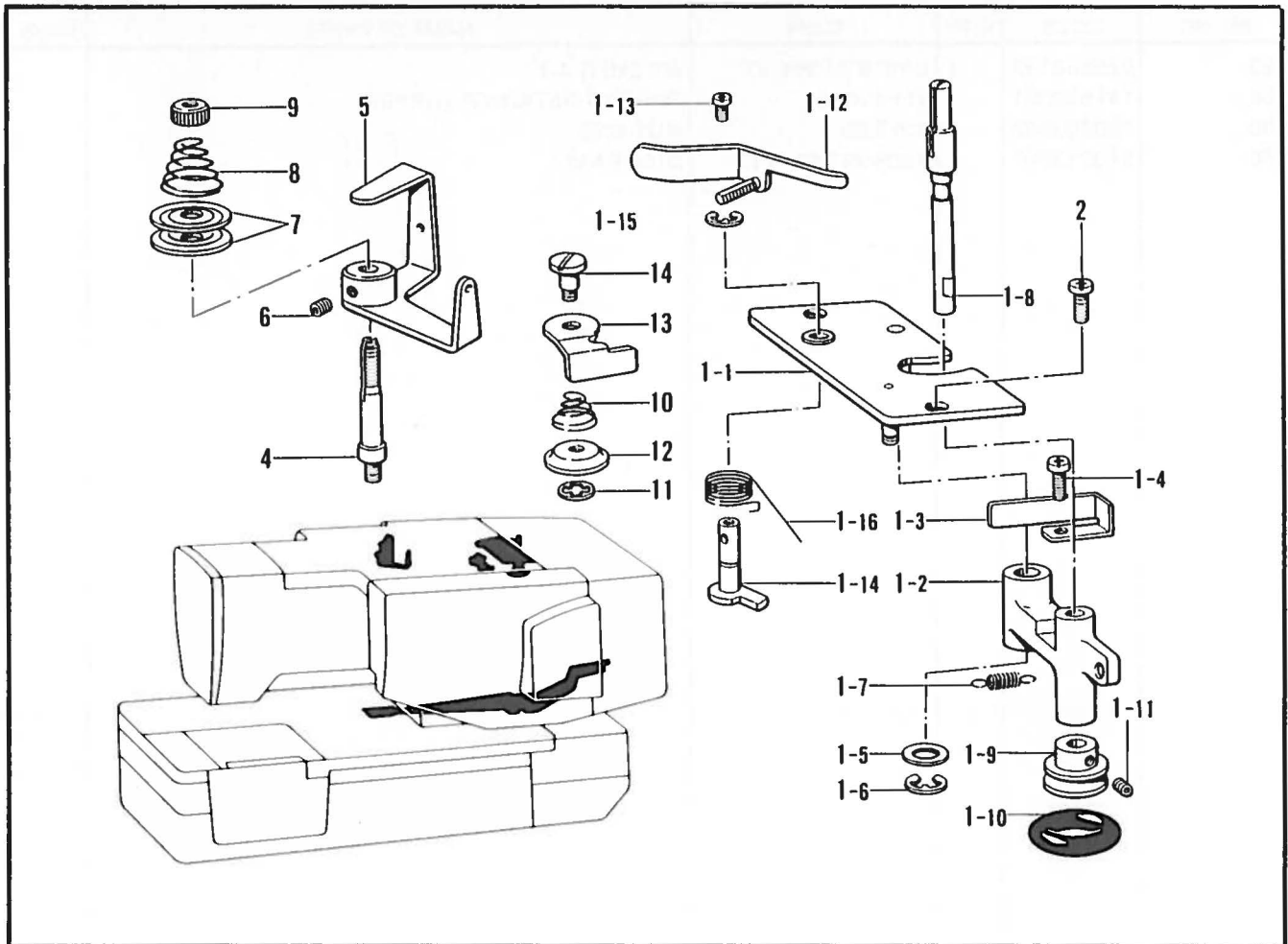

U. 糸巻装置 / Bobbin winder / Spuler /
 Mécanisme du bobineur / Mecanismo del devanador de la canilla

REF.NO.	CODE	Q'TY	ヒンメイ	NAME OF PARTS	RMKS
1	S01287006	1	イトマキクミ	BOBBIN WINDER ASSEMBLY	
1-1	S01288006	1	イトマキト"ダ"イクミ	BOBBIN WINDER BRACKET ASSEMBLY	
1-2	S01290001	1	イトマキウテ"	BOBBIN ARM WINDER FRAME	
1-3	S01292001	1	イトマキイタハ"ネ	SPRING	
1-4	062680812	1	ナヘ"コ437-40X8	SCREW 437X8	
1-5	025080132	1	ヒラサ"カ"ネシヨウ8	WASHER 8	
1-6	048060342	1	トメフE6	STOP RING E6	
1-7	S01294001	1	イトマキウテ"ハ"ネ	SPRING	
1-8	159252001	1	イトマキシ"ク	BOBBIN WINDER SHAFT	
1-9	154528001	1	イトマキクルマ	BOBBIN WINDER WHEEL	
1-10	120448001	1	ゴムフ	RUBBER RING	
1-11	014680622	2	アナトメネシ"4.37クホ"ミ	SCREW 4.37	
1-12	159253001	1	ホ"ビ"ンオサエ	BOBBIN PRESSER	
1-13	062670612	1	ナヘ"コ357-40X6	SCREW 357X6	
1-14	S01291001	1	イトマキカムシ"ク	SHAFT	
1-15	048050342	1	トメフE5	STOP RING E5	
1-16	S01293001	1	イトマキカムシ"クハ"ネ	SPRING	
2	062710812	2	ナヘ"コ476-32X8	SCREW 476X8	
4	159256001	1	イトマキチヨウシホ"ウ	BOBBIN WINDER THREAD TENSION STUD	
5	159257001	1	イトマキイトアンナイ	BOBBIN WINDER THREAD GUIDE	
6	014680622	1	アナトメネシ"4.37クホ"ミ	SCREW 4.37	
7	145446001	2	イトチヨウシサラ	TENSION DISC	
8	115188001	1	シユイトチヨウシハ"ネ	TENSION SPRING	
9	100136001	1	イトチヨウシナツト	TENSION CONTROL NUT	
10	144505000	1	イトアンナイハ"ネ	SPRING	
11	146200001	1	トメフCS4	STOP RING CS4	
12	146199001	1	イトツカミサラ	THREAD HOLDER DISC	
13	146198001	1	イトツカミメス	THREAD HOLDER KNIFE	
14	118764002	1	タ"ンネシ"4.37	STUD SCREW 4.37	

V: 上糸切り関係 / Upper thread trimmer mechanism / Oberer Fadenabschneider /
 Mécanisme de la coupe-fil supérieur / Mecanismo de la recortadura de hilo superior

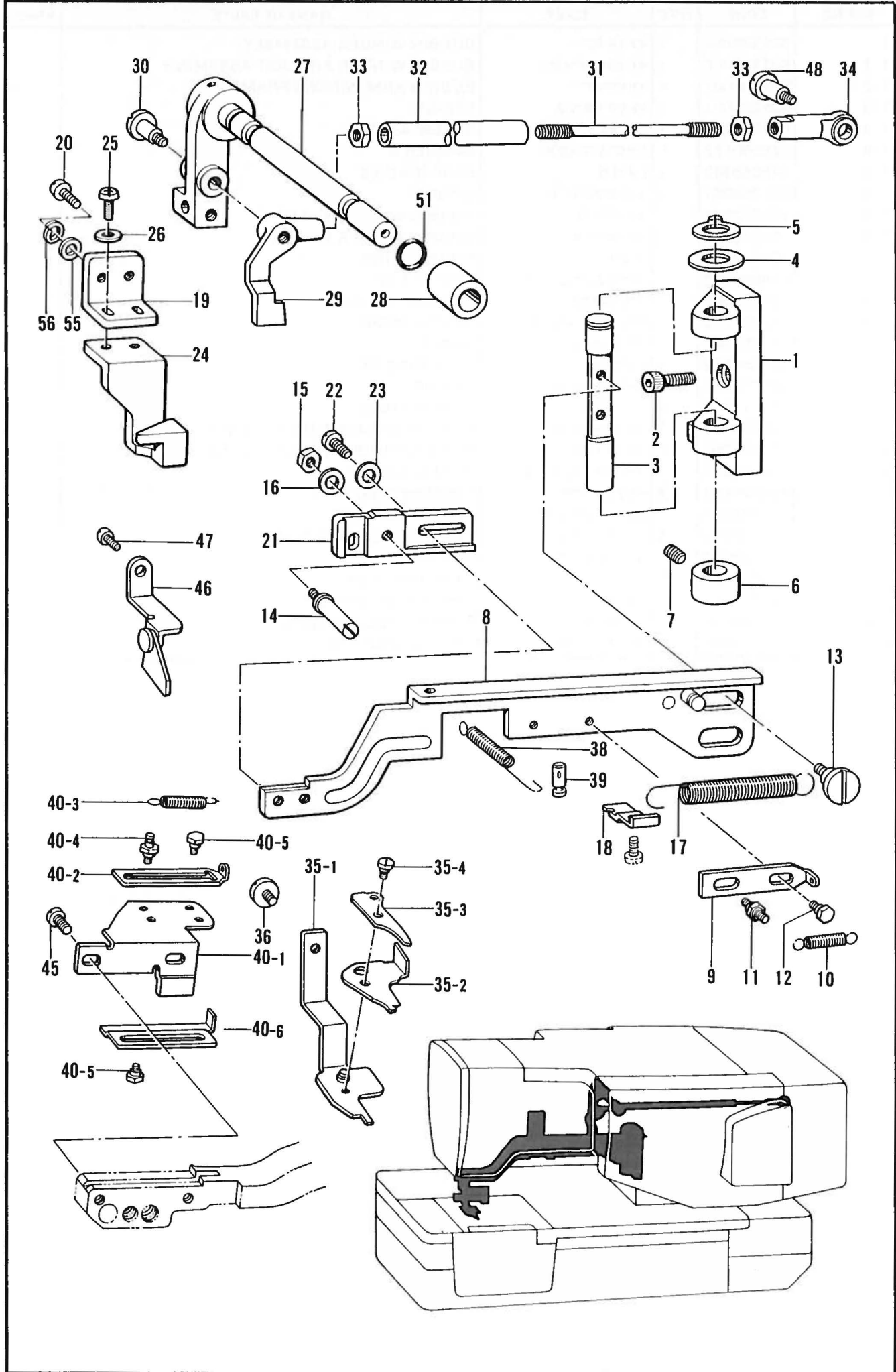

V. 上糸切り関係 / Upper thread trimmer mechanism / Oberer Fadenabschneider /
Mécánisme de la coupe-fil supérieur / Mecanismo de la recortadura de hilo superior

REF.NO.	CODE	Q'TY	ヒンメイ	NAME OF PARTS	RMKS
1	159335001	1	ウワイトキリシテント"ダイ	UPPER THREAD TRIMMING LEVER BRACKET	
2	018061622	2	アナボ"ルト6X16	BOLT 6X16	
3	159336001	1	ウワイトキリシテシ"ク	UPPER THREAD TRIMMING LEVER SHAFT	
4	115007001	1	サ"カ"ネ	WASHER	
5	048120142	1	トメワシ"クヨウC12	STOP RING (C12)	
6	117671002	1	セツトカラ"ー	SET COLLAR	
7	014770622	2	アナトメネシ"6.35クホ"ミ	SCREW 6.35	
8	159337101	1	ウワイトキリレハ"ークミ	UPPER THREAD TRIMMING LEVER	
9	159341001	1	ハサミハス"シクラツチイタ	UPPER THREAD TRIMMING CLUTCH PLATE	
10	159111001	1	Cクラツチアンナイハ"ネ	CUTTER CLUTCH GUIDE SPRING	
11	159948001	1	ハ"ネカケ	SPRING HOOK	
12	159113001	1	タ"ンネシ"3.18	STUD SCREW 3.18	
13	159342101	2	タ"ンネシ"5.95	STUD SCREW 5.95	
14	159343001	1	ハサミササエシ"ク	UPPER THREAD TRIMMING SUPPORTER STUD	
15	021680202	1	ナツト2シユ4.37	NUT 4.37	
16	025680132	1	ヒラサ"カ"ネシユウ4.37	WASHER 4.37	
17	159344001	1	ハサミモト"シハ"ネ	UPPER THREAD TRIMMING RETURNING SPRING	
18	159345001	1	ハ"ネカケ	SPRING HOOK	
19	159346101	1	ハサミハス"シアンナイ	UPPER THREAD TRIMMING CLUTCH GUIDE	
20	062681412	2	ナヘ"コ437-40X14	SCREW 437X14	
21	159017001	1	ウワイトキリレハ"-B	UPPER THREAD TRIMMING LEVER (B)	
22	062680612	2	ナヘ"コ437-40X6	SCREW 437X6	
23	025680232	2	ヒラサ"カ"ネチユウ4.37	WASHER 4.37	
24	159348101	1	ハサミハス"シカム	UPPER THREAD TRIMMING DETATCH CAM	
25	153057002	2	オクリイタシメネシ"	FEED PLATE SCREW	
26	025680232	2	ヒラサ"カ"ネチユウ4.37	WASHER 4.37	
27	159349001	1	ハサミオシレハ"ークミ	UPPER THREAD TRIMMING PUSHING LEVER	
28	159262000	1	オシレハ"-シ"クメタル	THREAD TRIMMING PUSHING LEVER BUSHING	
29	159354001	1	ウワイトキリレンカンササエ	UPPER THREAD TRIMMING CONNECTOR SUPPORT	
30	112404001	1	タ"ンネシ"5.95	STUD SCREW 5.95	
31	159355001	1	ウワイトキリレンカン	UPPER THREAD TRIMMING CONNECTOR	
32	159356001	1	ウワイトキリレンカンパイプ"	UPPER THREAD TRIMMING CONNECTOR PIPE	
33	106588003	2	ナツト5.95	NUT 5.95	
34	141492001	1	タマツキ"テクミ	ROUND JOINT ASSEMBLY	
35	159357001	1	ハサミクミ	UPPER THREAD TRIMMING ASSEMBLY	
35-1	159370001	1	ハサミDクミ	UPPER THREAD LOWER BLADE	
35-2	159373001	1	ハサミM	UPPER THREAD MIDDLE BLADE	
35-3	159374001	1	ハサミU	UPPER THREAD UPPER BLADE	
35-4	141514001	1	ハサミタ"ンネシ"	STUD SCREW	
36	115503001	1	シメネシ"4.37	SCREW 4.37	
38	159378001	1	ハサミサト"ウハ"ネ	UPPER THREAD TRIMMING DRIVING SPRING	
39	159379001	1	ミゾ"ツキヒ"ンBX6X18	GROOVED PIN 6X18	
40	S01018001	1	ハサミアンナイクミ	UPPER THREAD TRIMMING GUIDE ASSEMBLY	
40-1	159380001	1	ハサミアンナイ	UPPER THREAD TRIMMING GUIDE	
40-2	159381001	1	ハサミアンセ"ンイタ	UPPER THREAD TRIMMING SAFETY PLATE	
40-3	159111001	1	Cクラツチアンナイハ"ネ	CUTTER CLUTCH GUIDE SPRING	
40-4	159948001	1	ハ"ネカケ	SPRING HOOK	
40-5	159113001	3	タ"ンネシ"3.18	STUD SCREW 3.18	
40-6	159946001	1	ハサミアンセ"ンイタD	THREAD TRIMMING GUARD PLATE (D)	
45	062681012	2	ナヘ"コ437-40X10	SCREW 437X10	
46	159554001	1	ハサミニカ"シイタササエクミ	THREAD TRIMMING GUARD SUPPORTER ASSEMBLY	
47	062760812	1	ナヘ"コ595-28X8	SCREW 595X8	
48	141494001	1	タマツキ"テタ"ンネシ"	ROUND JOINT STUD SCREW	
51	081006670	1	Oリング"PW6	O RING PW6	
55	025680232	2	ヒラサ"カ"ネチユウ4.37	WASHER 4.37	
56	028680242	2	ハ"ネサ"カ"ネ2-4.37	SPRING WASHER 2-4.37	

V. 下糸切り関係 / Upper thread trimmer mechanism / Oberer Fadenabschneider /
 Mécanisme de la coupe-fil supérieur / Mecanismo de la recortadura de hilo superior

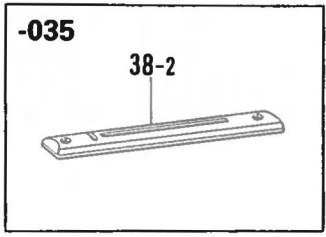
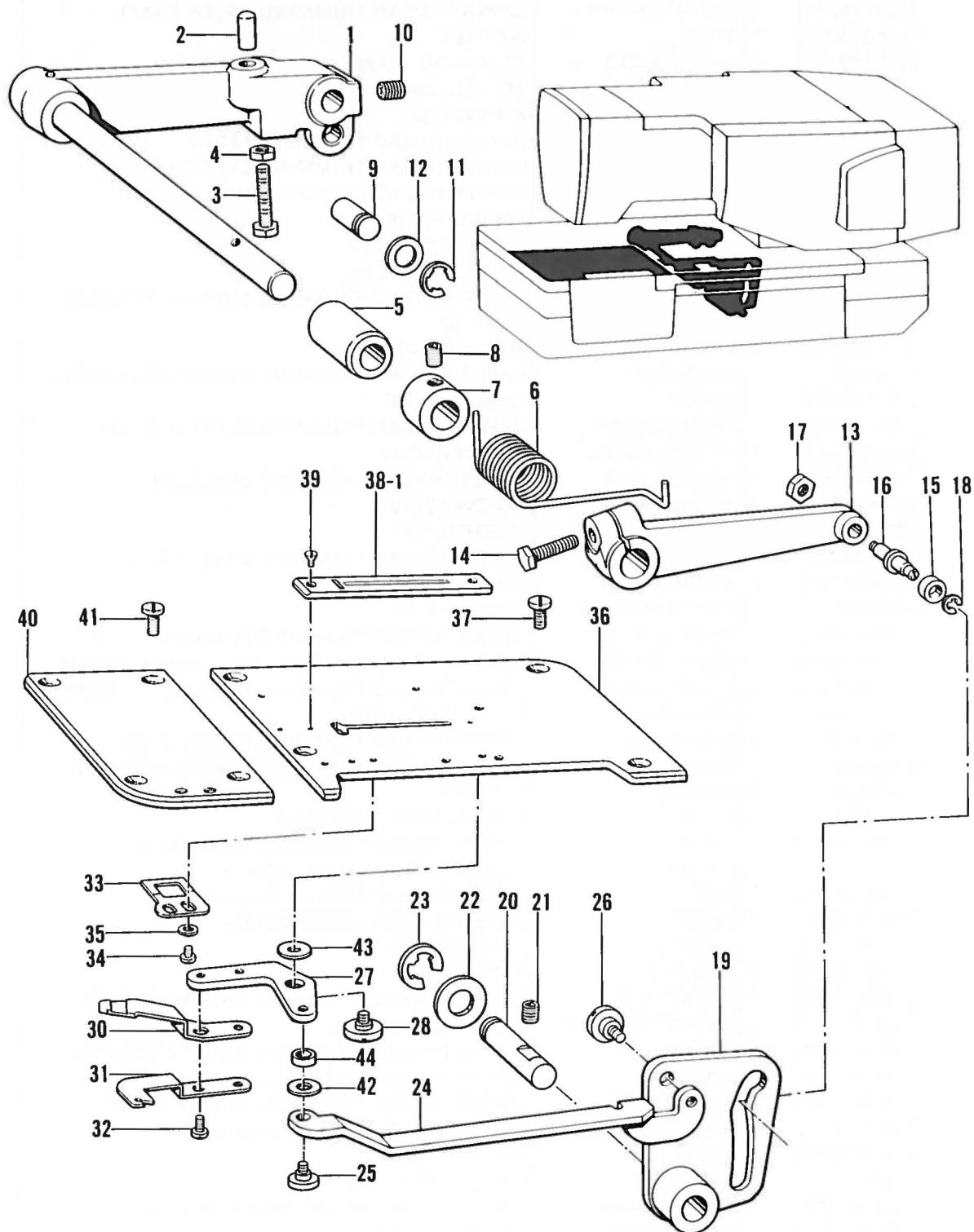

W. 下糸切り関係 / Lower thread trimmer mechanism / Unterer Fadenabschneider /
 Mécanisme de la coupe-fil inférieur / Mecanismo de la recortadura de hilo inferior

REF.NO.	CODE	Q'TY	ヒンメイ	NAME OF PARTS	RMKS
1	159259201	1	シタイトキリレハ"ークミ	LOWER THREAD CUTTER LEVER ASSEMBLY	
2	159118000	1	Cサト"ウシ"ククツシヨソ	CUTTER DRIVING SHAFT CUSHION	
3	017762202	1	ボ"ルト5.95X22	BOLT 5.95X22	
4	106588003	1	ナツト5.95	NUT 5.95	
5	159768000	1	シタイトキリレハ"シ"クメタル	LOWER THREAD CUTTING LEVER SHAFT BUSHING	
6	159263001	1	シタイトキリレハ"ーハ"ネ	LOWER THREAD CUTTING LEVER SPRING	
7	141351001	1	セツトカラー	SET COLLAR	
8	014770622	1	アナトメネシ"6.35クホ"ミ	SCREW 6.35	
9	159264001	1	シタイトキリレハ"ーヒ"ン	LOWER THREAD CUTTING LEVER PIN	
10	014760622	1	アナトメネシ"5.95	SCREW 5.95	
11	048060342	1	トメフE6	STOP RING E6	
12	025080232	1	ヒラサ"カ"ネチユウ8	WASHER 8	
13	159265001	1	シタイトカムレハ"ー	LOWER THREAD CUTTING CAM LEVER	
14	017762012	1	ボ"ルト5.95X20	BOLT 5.95X20	
15	107744001	1	コロ	ROLLER	
16	141519001	1	イトキリサト"ウカムコロシ"ク	ROLLER STUD	
17	110161004	1	ナツト4.76	NUT 4.76	
18	048030342	1	トメフE3	STOP RING E3	
19	159266101	1	シタイトキリカム	LOWER THREAD CUTTING CAM	
20	159267001	1	シタイトキリカムシ"ク	LOWER THREAD CUTTING CAM SHAFT	
21	014760622	1	アナトメネシ"5.95	SCREW 5.95	
22	110494001	1	サ"カ"ネ	WASHER	
23	048080342	1	トメフE8	STOP RING E8	
24	159268001	1	シタイトキリリンク	LOWER THREAD CUTTING LINK	
25	159269001	1	シタイトキリリンクタ"ンネシ"	LOWER THREAD CUTTING LINK STUD SCREW	
26	159270001	1	シタイトキリカムタ"ンネシ"	LOWER THREAD CUTTING CAM STUD SCREW	
27	159271001	1	メスサト"ウレハ"ー	MOVABLE KNIFE DRIVING LEVER	
28	159272001	1	メスサト"ウレハ"タ"ンネシ"	MOVABLE KNIFE DRIVING LEVER STUD SCREW	
30	159274001	1	シタイトイト"ウハ	MOVABLE KNIFE	
31	159275101	1	シタイトサハ"キ	LOWER THREAD RETAINER	
32	062670512	2	ナヘ"コ357-40X5	SCREW 357X5	
33	159276201	1	シタイトコテイハ	FIXED KNIFE	
34	110215002	2	シメネシ"3.57	SCREW 3.57	
35	025350132	2	ヒラサ"カ"ネシヨウ	WASHER	
36	159277101	1	ヘ"ースハリイタ	BASE PLATE	
37	145318001	4	シメネシ"4.37	SCREW 4.37	
38-1	159759001	1	ハリイタ1.4S (-025)	NEEDLE PLATE (1.4S) (-025)	
38-2	S01469001	1	ハリイタ1.2 (-035)	NEEDLE PLATE (1.2) (-035)	
39	145247001	2	サラネシ"2.38	SCREW 2.38	
40	159281001	1	ヌノイタ	CLOTH PLATE	
41	145318001	4	シメネシ"4.37	SCREW 4.37	
42	S00901001	1	メスサト"ウレハ"サ"カ"ネU	WASHER (U)	
43	S00902001	1	メスサト"ウレハ"サ"カ"ネD	WASHER (D)	
44	S00903001	1	メスサト"ウレハ"ーカラー	COLLAR	

Y. 特別注文部品 / Option parts / Sonderzubehör /
Pièces en option / Piezas opcionales

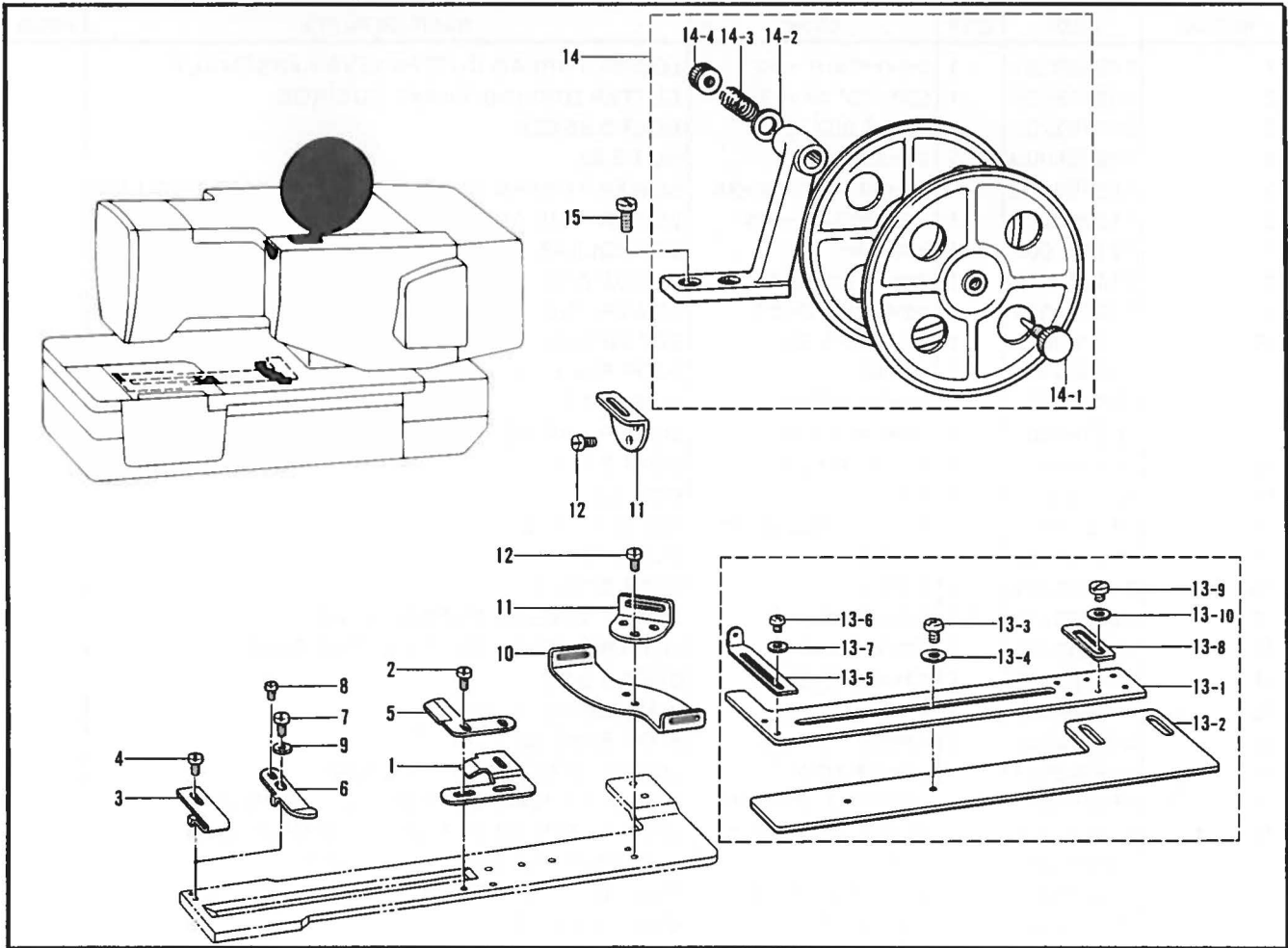

Y. 特別注文部品 / Option parts / Sonderzubehör /
Pièces en option / Piezas opcionales

REF NO.	CODE	Q'TY	ヒンメイ	NAME OF PARTS	RMKS
1	144998001	1	テープオサIB	TAPE PRESSER (B)	
2	105288002	2	シメネジ"2.38	SCREW 2.38	
3	144997001	1	テープオサIA	TAPE PRESSER (A)	
4	122771002	2	シメネジ"2.38	SCREW 2.38	
5	144999001	1	テープオサIC	TAPE PRESSER (C)	
6	144628001	1	テープオサIF	TAPE PRESSER (F)	
7	122771002	1	シメネジ"2.38	SCREW 2.38	
8	105970001	1	シメネジ"2.38	SCREW 2.38	
9	110067001	1	カラー	COLLAR	
10	143749001	1	テープアンナイシタ	TAPE GUIDE (LOWER)	
11	143748001	2	テープアンナイウエ	TAPE GUIDE (UPPER)	
12	062660416	4	ナヘ"コ318-40X4	SCREW 318X4	
13	S06138001	1	ジ"ョウキ"クミ	RULER ASSEMBLY	
13-1	S06139001	1	ジ"ョウキ"A	RULER (A)	
13-2	S06140001	1	ジ"ョウキ"B	RULER (B)	
13-3	062680512	2	ナヘ"コ437-40X5	SCREW 437X5	
13-4	025680232	2	ヒラサ"カ"ネチュウ4.37	WASHER 4.37	
13-5	146000001	1	ハサミササエ	THREAD TRIMMING SUPPORTER	
13-6	062670412	2	ナヘ"コ357-40X4	SCREW 357X4	
13-7	105161003	2	サ"カ"ネ	WASHER	
13-8	141620001	1	ホ"ウシイタハ"ランス	PREVENTION PLATE BALANCER	
13-9	101671002	2	シメネジ"4.37	SCREW 4.37	
13-10	025680132	2	ヒラサ"カ"ネシヨウ4.37	WASHER 4.37	
14	143767006	1	テープワインダ"ー"ダイクミ	TAPE WINDER BRACKET ASSEMBLY	
14-1	143980001	1	ツマミネジ"	THUMB SCREW	
14-2	108494001	1	サ"カ"ネ	WASHER	
14-3	108495001	1	テープワインダ"ー"オシハ"ネ	SPRING	
14-4	100136001	1	イトチョウシナット	THREAD TENSION NUT	
15	107407003	2	シメネジ"4.37	SCREW	

Z. 付属品関係 / Accessories / Zubehör / Accessoires / Accesorios

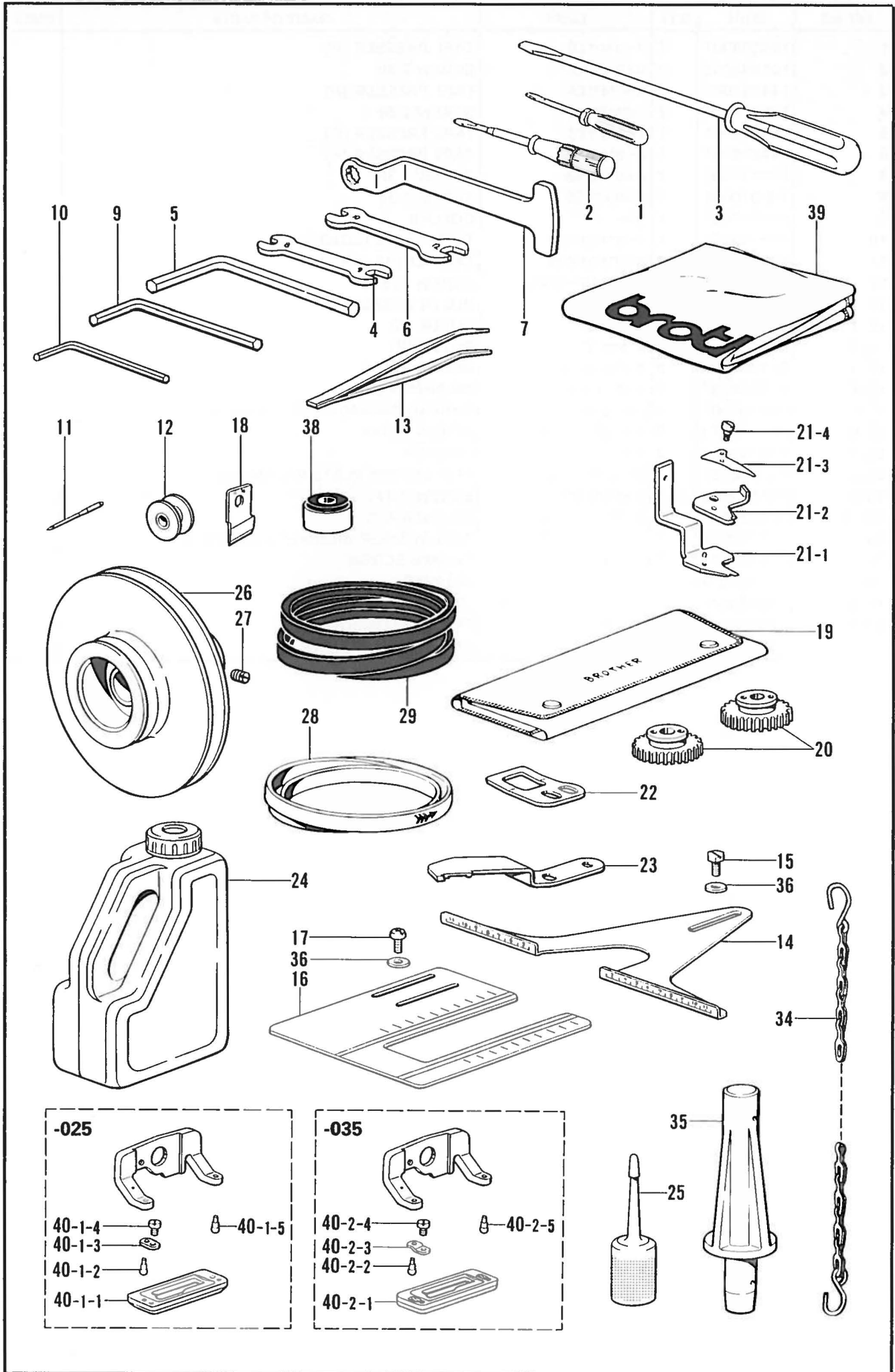

Z. 付属品関係/Accessories/Zubehör/
Accessoires/Accessorios

REF. NO.	CODE	Q'TY	ヒンメイ	NAME OF PARTS	RMKS
1	142443001	1	ネジ"マフシ1.9X52	SCREW DRIVER 1.9X52	
2	118837001	1	ネジ"マフシ3.4X70	SCREW DRIVER 3.4X70	
3	101572101	1	ネジ"マフシ5.5X190	SCREW DRIVER 5.5X190	
4	100887001	1	スパナ8X9	SPANNER 8X9	
5	115157001	1	6カクホ"ウスハ"ナ6	ALLEN WRENCH 6	
6	107780001	1	スパナ10X12	SPANNER 10X12	
7	152765001	1	メガ"ネレンチ10	WRENCH 10	
9	150335001	1	6カクホ"ウスハ"ナ5	ALLEN WRENCH 5	
10	142721001	1	6カクホ"ウスハ"ナ3	ALLEN WRENCH 3	
11	*	1	ミシンハリ1906	NEEDLE 1906	
12	159158001	3	ホ"ビ"ン	BOBBIN	
13	117466000	1	ヒ"ンセット	TWEEZERS	
14	S00807001	1	ヨコジ"ヨウキ"	RULER	
15	017680514	2	ホ"ルト4.37X5	BOLT 4.37X5	
16	S00806101	1	タテジ"ヨウキ"	RULER	
17	062681012	2	ナヘ"コ437-40X10	SCREW 437X10	
18	*	1	カツタ	CUTTER	
19	142745002	1	チェンジ"キ"ヤケース	CHANGE GEAR BOX	
20	*	1	チェンジ"キ"ヤ	GEAR	
21	159357001	1	ハサミクミ	UPPER THREAD TRIMMING ASSEMBLY	
21-1	159370001	1	ハサミDクミ	UPPER THREAD LOWER BLADE	
21-2	159373001	1	ハサミM	UPPER THREAD MIDDLE BLADE	
21-3	159374001	1	ハサミU	UPPER THREAD UPPER BLADE	
21-4	141514001	1	ハサミタ"ンネジ"	STUD SCREW	
22	159276201	1	シタイトコテイハ	FIXED KNIFE	
23	159274001	1	シタイトイト"ウハ	MOVABLE KNIFE	
24	154702001	1	オイルタンク	OIL TANK	
25	S06701000	1	ホ"リオイルラークミ	OILER	
26	*	1	モータプ"ーリ	MOTOR PULLEY	
27	151605002	2	トメネジ"5.95	SCREW 5.95	
28	141711100	1	ヒラヘ"ルト	BELT	
29	*	*	Vヘ"ルト	V BELT	
34	149247001	2	クサリクミ	CHAIN ASSEMBLY	
35	159384001	1	トウフ"ササエマクラ	HEAD REST	
36	116662003	2	サ"カ"ネ	WASHER	
38	146254001	4	モータカンサ"	COLLAR	
39	144226001	1	-----	HEAD COVER	
40-1	159764001	1	ヌノツカミ16RSクミ (-025)	UPPER CLAMPING FOOT ASSEMBLY (16RS) (-025)	
40-1-1	159761001	1	ヌノツカミ16RS	UPPER CLAMPING RUBBER FOOT (16RS)	
40-1-2	159926001	1	ヌノツカミササエヒ"ン L	CLAMPING FOOT SUPPORT PIN (LARGE)	
40-1-3	107401001	2	ヌノツカミササエイタハ"ネ	PLATE SPRING	
40-1-4	107404001	2	シメネジ"1.98	SCREW 1.98	
40-1-5	159927001	1	ヌノツカミササエヒ"ン S	CLAMPING FOOT SUPPORT PIN (SMALL)	
40-2	S01466001	1	ニツトヨウヌノツカミ16クミ (-035)	UPPER CLAMPING FOOT ASSEMBLY (16MM) (FOR KNIT) (-035)	
40-2-1	145136001	1	ニツトヨウヌノツカミS	UPPER CLAMPING RUBBER FOOT (16MM)	
40-2-2	159926001	1	ヌノツカミササエヒ"ン L	CLAMPING FOOT SUPPORT PIN (LARGE)	
40-2-3	144707001	2	ヌノツカミササエイタハ"ネ	PLATE SPRING	
40-2-4	107404001	2	シメネジ"1.98	SCREW 1.98	
40-2-5	159927001	1	ヌノツカミササエヒ"ン S	CLAMPING FOOT SUPPORT PIN (SMALL)	

※ 付属品の明細は変更することがあります。

※ The details of included accessories are subject to change.

※ Änderungen in der Aufstellung der Mitgelieferten Zubehöre sind vorbehalten.

※ Les détails des accessoires inclus sont sujets à des changements.

※ Los detalles de los accesorios incluidos pueden variar.

Z. 付屬品關係 / Accessories / Zubehör /
Accessoires / Accesorios

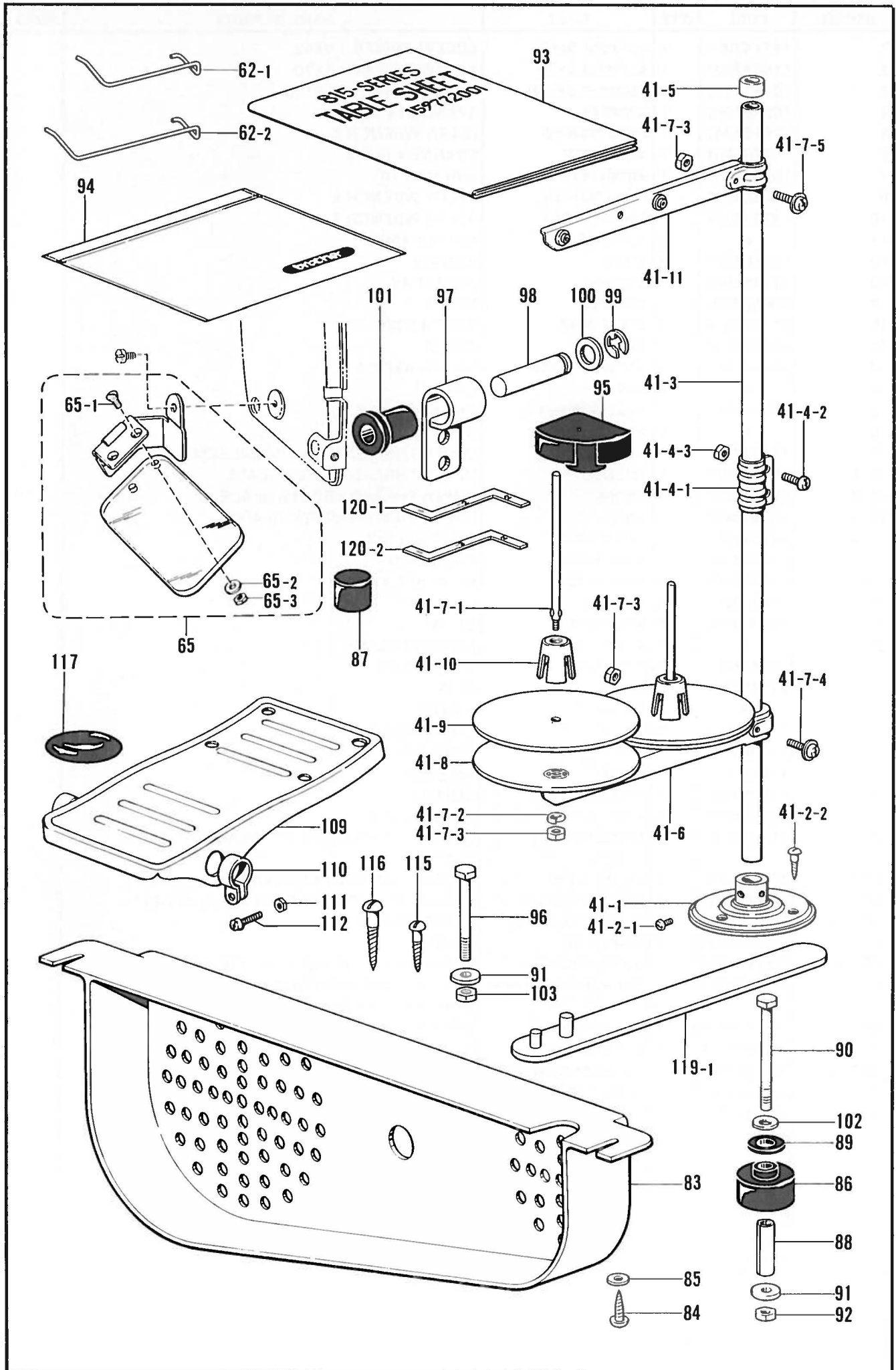

Z. 付属品関係/Accessories/Zubehör/
Accessoires/Accessorios

REF.NO.	CODE	Q'TY	ヒンメイ	NAME OF PARTS	RMKS
41	S02761001	1	イトタテタ"イクミ2	COTTON STAND ASSEMBLY 2	
41-1	150189002	1	フ"ラケツト	COTTON STAND BASE	
41-2	S02773001	1	フ"ラケツトネジ"セット	COTTON STAND BASE SCREW SET	
41-2-1	062060806	2	ナヘ"コ6X8	SCREW 6X8	
41-2-2	031452206	3	マルモク45X22	SCREW 45X22	
41-3	150172002	2	コラムパイプ	COLUMN PIPE	
41-4	150106002	1	コラムシ"ョイントクミ	COLUMN JOINT ASSEMBLY	
41-4-1	150173002	1	コラムシ"ョイント	COLUMN JOINT	
41-4-2	062501406	2	ナヘ"コ5X14	SCREW 5X14	
41-4-3	021500106	2	1シユナツト5	NUT 5	
41-5	150174000	1	コラムキャツプ	COLUMN CAP	
41-6	S02778001	1	スプ"ールホルタ"-2	SPOOL HOLDER 2	
41-7	S02780001	1	スプ"ールネジ"セット2	SPOOL SCREW SET 2	
41-7-1	150179002	2	スプ"ールシ"クB	SPOOL SHAFT (B)	
41-7-2	028050246	2	ハ"ネサ"カ"ネ2-5	SPRING WASHER 2-5	
41-7-3	021500106	4	1シユナツト5	NUT 5	
41-7-4	050503006	1	ナヘ"コヒラサ"5X30	SCREW 5X30	
41-7-5	050501406	1	ナヘ"コヒラサ"5X14	SCREW 5X14	
41-8	150180000	2	ウケサ"ラ	SPOOL STAND BASE	
41-9	150182000	2	スプ"ールマット	SPOOL MAT	
41-10	126863001	2	スプ"ールクツシヨソ	SPOOL CUSHION	
41-11	S02786001	1	スレツト"ハンガ"ークミ2	THREAD HANGER ASSEMBLY 2	
62-1	159079000	1	-----	FINGER GUARD (SMALL)	
62-2	159080000	1	-----	FINGER GUARD (MIDDLE)	
65	143971001	1	アイガ"ート"クミ	PLASTIC EYE GUARD ASSEMBLY	
65-1	S01700002	2	マルサラネジ"3.18X7	SCREW 3.18X7	
65-2	025030232	2	ヒラサ"カ"ネチユウ3	WASHER 3	
65-3	021660102	2	ナツト1シユ3.18	NUT 3.18	
83	159332000	1	V"ベルトカハ"ー	V-BELT COVER	
84	032422003	2	+マルモクネジ"4.1X20	SCREW 4.1X20	
85	116662003	2	サ"カ"ネ	WASHER	
86	158827000	4	ヘ"ット"ク"イクツシヨソA	BED BASE CUSHION (A)	
87	158828000	1	ヘ"ット"ク"イクツシヨソB	BED BASE CUSHION (B)	
88	159715001	4	ス"パ"ー6X25	SPACER 6X25	
89	159458000	4	ゴ"ムシ"ート	RUBBER SHEET	
90	159910001	4	ホ"ルト6X75	BOLT 6X75	
91	115947001	6	サ"カ"ネ	WASHER	
92	021060102	4	ナツト1シユ6	NUT 6	
93	159772101	1	テ"ーブルシ"ート	TABLE SHEET	
94	122991001	1	フ"ソ"クヒソ"ホ"リフクロ	ACCESSORY BAG	
95	159454000	1	ヘ"ット"クツシヨソF	BED CUSHION (FRONT)	
96	017066002	2	ホ"ルト6X60	BOLT 6X60	
97	158830001	2	ヒソ"シ"	HEAD HINGE	
98	158831001	2	ヒソ"シ"ヒ"ソ	HEAD HINGE PIN	
99	048080342	2	トメワE8	STOP RING E8	
100	025100132	2	ヒラサ"カ"ネシヨウ10	WASHER 10	
101	158832000	2	ヒソ"シ"ヒ"ソササエゴ"ム	HEAD HINGE PIN SUPPORTER RUBBER	
102	025060332	4	ヒラサ"カ"ネタ"イ6	WASHER 6	
103	021060102	2	ナツト1シユ6	NUT 1-6	
109	117437102	2	オサエアケ"フミイタ	FOOT PEDAL	
110	116016001	4	ヘ"タルトメ	PEDAL STOPPER	
111	021400106	4	1シユナツト4	NUT 4	
112	062401406	4	ナヘ"コ4X14	SCREW 4X14	
115	101118001	1	マルモクネジ"4.5X20	SCREW 4.5X20	
116	101125000	1	マルモクネジ"6.2X32	SCREW 6.2X32	
117	120448001	1	ゴ"ムワ	RUBBER RING	
119	S12609001	1	ハ"ネハス"シクミ	SPRING DETACHER ASSEMBLY	
119-1	S11462001	1	ハ"ネハス"シ	SPRING DETACHER	
120-1	S13595001	1	テ"アイケ"ーシ"815-2	GAUGE 815-2	
120-2	S13596001	1	テ"アイケ"ーシ"815-3	GAUGE 815-3	

※ 付属品の明細は変更することがあります。

※ The details of included accessories are subject to change.

※ Änderungen in der Aufstellung der Mitgelieferten Zubehöre sind vorbehalten.

※ Les détails des accessoires inclus sont sujets à des changements.

※ Los detalles de los accesorios incluidos pueden variar.

仕様別部品一覧表 / GAUGE PARTS LIST / LEHRENLISTE /
 LISTE DES PIÈCES D'ECARTEMENT / LISTA DE PIEZAS DE CALIBRADORES

REF.NO.	サブクラス SUB CLASS	-025	-035			
REF.NO.	ヒンメイ PARTS					
B-10	ミシンハリ1906 #80 (#12) ----- NEEDLE 1906 #80 (#12)	S13594080	←			
B-10	----- NEEDLE 1906 #90 (#14)	S13594090	-----			
K-15	チェンジ"キ"ヤ30 ----- GEAR 30	-----	141376000			
K-15	チェンジ"キ"ヤ34 ----- GEAR 34	141378000	-----			
K-15	チェンジ"キ"ヤ42 ----- GEAR 42	141382000	-----			
K-15	チェンジ"キ"ヤ46 ----- GEAR 46	-----	141384000			
Z-11	ミシンハリ1906 #80 (#12) ----- NEEDLE 1906 #80 (#12)	S13594080	←			
Z-11	----- NEEDLE 1906 #90 (#14)	S13594090	-----			
Z-20	チェンジ"キ"ヤ30 ----- GEAR 30	141376000	-----			
Z-20	チェンジ"キ"ヤ34 ----- GEAR 34	-----	141378000			
Z-20	チェンジ"キ"ヤ36 ----- GEAR 36	141379000	←			
Z-20	チェンジ"キ"ヤ38 (コスウ:2) ----- GEAR 38 (Q'TY:2)	141380000	←			
Z-20	チェンジ"キ"ヤ40 ----- GEAR 40	141381000	←			
Z-20	チェンジ"キ"ヤ42 ----- GEAR 42	-----	141382000			
Z-20	チェンジ"キ"ヤ46 ----- GEAR 46	141384000	-----			

REF.NO.	サブクラス SUB CLASS	コクナイヨウ FOR DOMESTIC 50HZ	コクナイヨウ FOR DOMESTIC 60HZ	エシユツヨウ FOR EXPORT 50HZ	エシユツヨウ FOR EXPORT 60HZ	
	ヒンメイ PARTS					
Z-18	カッタ 5/8 ----- CUTTER 5/8	107205001	←	←	←	
Z-18	カッタ 3/8 ----- CUTTER 3/8	109837001	←	←	←	
Z-18	カッタ 3/4 ----- CUTTER 3/4	107207001	←	←	←	
Z-18	カッタ 1 ----- CUTTER 1	107210001	←	←	←	
Z-26	----- ----- MOTOR PULLEY 3600	-----	-----	159633001	159387001	
Z-26	モーターP3200 ----- -----	159634001	159386001	-----	-----	
Z-26	----- ----- MOTOR PULLEY 3600	-----	-----	S00392000 (England)	S00393000 (U.S.A)	
Z-29	VベルトM27 (コスタ:2) ----- V BELT M27 (Q'TY:1)	-----	082102790	-----	082102790	
Z-29	VベルトM28 (コスタ:1) ----- V BELT M28 (Q'TY:1)	082102890	-----	082102890	←	
Z-29	VベルトM29 (コスタ:1) ----- -----	082102990	-----	-----	-----	
Z-29	Vベルト30 (コスタ:1) ----- V BELT M30 (Q'TY:1)	-----	-----	082103090	-----	
	----- -----					
	----- -----					
	----- -----					
	----- -----					
	----- -----					
	----- -----					
	----- -----					

カッタ・Cutter

109837-001 	107200-001 	S03278-001 	107205-001 	107204-001 	107207-001 	109838-001 	107210-001 	143780-001 	147987-001
9.85	12.7	14.3	15.87	11.11	19.05	22.22	25.4	32	44.5
147941-001 	147233-001 	S01271-001 	S03280-001 	S01273-001 	S01274-001 	S01275-001 	S01276-001 	S01272-001 	
48	50	9.85	14.3	12.7	15.87	19.05	22.23	11.11	

ヌノツカミ
Upper Clamping Foot Assembly

159072-001 16mm(-2) 147113-001 	158982-001 16mm(-2) 159581-001 	159074-001 25mm(-2) 159579-001 	159217-001 25mm(-2) 159582-001 	159076-001 32mm(-2) 159580-001 		
159764-001 16mmRS(-2) 159761-001 	159765-001 25mmRS(-2) 159762-001 	159766-001 32mmRS(-2) 159763-001 	S01466-001 16mm(-3) 145136-001 	S01467-001 25mm(-3) 144630-001 	S01468-001 32mm(-3) 144632-001 	カッターウケ Plastic Plate S01270-001

ハリイタ・Needle Plate

159278-001 1.2mm(-2) 	S01469-001 1.2mm(-3) 	159279-001 1.4mm(-2) 	159280-001 1.6mm(-2) 	159758-001 1.2mmS(-2)
159759-001 1.4mmS(-2) 	159760-001 1.6mmS(-2) 	S01269-001 1.2mmS(-2) 	S08006-001 1.2mm(-3) 	カッターウケ Plastic Plate 156612-001

ナーン部一覽表/GAUGE PARTS LIST/LEHRENLISTE/
LIST DES PIÈCES D'ÉCARTEMENT / LISTA DE PIEZAS CALIBRADORAS

ゲージ部品一覧表 / GAUGE PARTS LIST / LEHRENLISTE /
LIST DES PIÈCES D'ECARTEMENT / LISTA DE PIEZAS CALIBRADORAS

チェンジギヤ
Change Gear

針数 Number of Stitches	チェンジギヤ L Change Gear L	チェンジギヤ R Change Gear R	針数 Number of Stitches	チェンジギヤ L Change Gear L	チェンジギヤ R Change Gear R
347	(54) 141388-000	(22) 141372-001	127	(36) 141379-000	(40) 141381-000
306	(52) 141387-000	(24) 141373-001	114	(34) 141378-000	(42) 141382-000
271	(50) 141386-000	(26) 141374-000	103	(32) 141377-000	(44) 141383-000
242	(48) 141385-000	(28) 141375-000	92	(30) 141376-000	(46) 141384-000
216	(46) 141384-000	(30) 141376-000	82	(28) 141375-000	(48) 141385-000
194	(44) 141383-000	(32) 141377-000	73	(26) 141374-000	(50) 141386-000
174	(42) 141382-000	(34) 141378-000	65	(24) 141373-001	(52) 141387-000
157	(40) 141381-000	(36) 141379-000	58	(22) 141372-001	(54) 141388-000
141	(38) 141380-000	(38) 141380-000			

回転数別モーターリとVベルト組合せ / MOTOR PULLEY AND V-BELT SELECTION /
AUSWAHL DER RIEMENSCHLEIBEN UND ANTRIEBSRIEMEN /
MOTEUR ET DES LISTE DES PIÈCES COURROIES TRAPEZOIDALES /
ELECCION DE POLEA DE MOTOR Y CORREA TRAPEZOIDAL

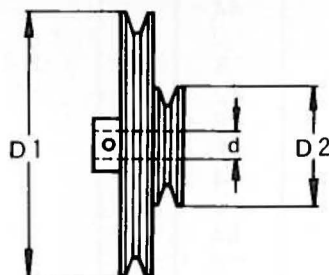

回転数 Machine Speed	周波数 Frequency	モーターリ Motor Pulley			高速Vベルト(インチ)	低速Vベルト(インチ)
		外径・内径 Outside Inside Diameter	穴径 Core	部品コード Parts No	High Speed V-belt	Low Speed V-belt
4000	50 Hz	D1 = 157.5 D2 = 65.3	d = 14	159632-001	082103-190 (M31)	082102-890 (M28)
			d = 15.88	S00396-001		
	60 Hz	D1 = 132.2 D2 = 51.7	d = 14	159385-001	082102-990 (M29)	082102-790 (M27)
			d = 19.05	S00397-001		
3600	50 Hz	D1 = 142.4 D2 = 64.0	d = 14	159633-001	082103-090 (M30)	082102-890 (M28)
			d = 15.88	S00392-001		
			d = 16	S01243-001		
	60 Hz	D1 = 119.5 D2 = 54.1	d = 14	159387-001	082102-890 (M28)	082102-790 (M27)
			d = 16	S01242-001		
			d = 19.05	S00393-001		
3200	50 Hz	D1 = 127.2 D2 = 63.2	d = 14	159634-001	082102-990 (M29)	082102-890 (M28)
			d = 15.88	S00394-001		
			d = 16	S01944-001		
	60 Hz	D1 = 106.9 D2 = 56.8	d = 14	159386-001	082102-790 (M27)	082102-790 (M27)
			d = 16	S01879-001		
			d = 19.05	S00395-001		
2800	60 Hz	D1 = 91.5 D2 = 56.8	d = 14	S12564-001	082102-690 (M26)	082102-790 (M27)

索引/INDEX/VERZEICHNIS/
INDEX/INDICE

CODE	REF.NO.	PAGE
S00306001	A - 102	4
S00392000	Z - 26	52
S00393000	Z - 26	52
S00806101	Z - 16	52
S00807001	Z - 14	52
S00850000	A - 87	4
S00862000	C - 36	8
S00901001	W - 42	48
S00902001	W - 43	48
S00903001	W - 44	48
S01009101	A - 104	4
S01018001	V - 40	46
S01047001	S - 13	36
S01109001	R - 17	34
S01143001	B - 5-2	6
S01236001	M - 23	24
S01287006	U - 1	44
S01288006	U - 1-1	44
S01290001	U - 1-2	44
S01291001	U - 1-14	44
S01292001	U - 1-3	44
S01293001	U - 1-16	44
S01294001	U - 1-7	44
S01304001	D - 17-2	10
S01319001	C - 27	8
S01466001	Z - 40-2	52
S01467001	M - 48-2	26
S01469001	W - 38-2	48
S01470001	M - 42-2	24
S01698001	E - 5	14
S01700002	Z - 65-1	54
S01794001	G - 5	16
S01795000	N - 32	28
S02761001	Z - 41	54
S02773001	Z - 41-2	54
S02778001	Z - 41-6	54
S02780001	Z - 41-7	54
S02786001	Z - 41-11	54
S02807001	N - 78	30
S02972101	R - 1	34
S02974001	A - 106	4
S02975001	M - 53	26
S03238000	S - 76	38
S03239000	S - 77	38
S06138001	Y - 13	50
S06139001	Y - 13-1	50
S06140001	Y - 13-2	50
S06701000	Z - 25	52
S07849001	F - 1-1	16
S07850001	F - 1-2	16
S07851001	F - 1-5	16
S07852000	F - 1-15	16
S09477001	R - 11-1-3-1	34
	R - 11-2-3-1	34
S09566001	S - 79	38
S11309001	E - 12	14
S11453101	R - 11-2	34
S11454201	R - 11-2-1	34
S11462001	Z - 119-1	54
S12609001	Z - 119	54
S13594080	B - 10	6
	Z - 11	52
S13594090	B - 10	6
	Z - 11	52
S13595001	Z - 120-1	54
S13596001	Z - 120-2	54
S13633001	K - 8	20

CODE	REF.NO.	PAGE
S13634001	K - 5	20
S13635001	K - 7	20
S13649001	M - 54	26
S13650001	M - 55	26
S13651001	M - 33	24
S13652006	M - 24	24
S13713001	T - 56	42
S13727001	E - 21	14
S14154001	R - 20	34
S14190001	A - 110	4
S15855000	A - 7	2
S17062000	A - 5	2
S17063000	S - 80	38
014679320	C - 19	8
014680622	D - 17-11	10
	D - 17-14	10
	D - 17-7	10
	H - 5	18
	N - 11-2	28
	N - 9	28
	P - 9	32
	T - 21	40
	U - 1-11	44
	U - 6	44
014760622	A - 13	2
	A - 79	4
	B - 14	6
	B - 16	6
	B - 7	6
	C - 30	8
	C - 6	8
	D - 12	10
	D - 30	10
	D - 6	10
	D - 8	10
	E - 11	14
	E - 17	14
	E - 30	14
	F - 1-4	16
	F - 1-9	16
	G - 1-6	16
	G - 10	16
	J - 1-8	18
	L - 11	22
	L - 24	22
	L - 3	22
	L - 6	22
	M - 15	24
	M - 26	24
	M - 51	26
	M - 52	26
	N - 14	28
	N - 19	28
	N - 7	28
	Q - 12	32
	Q - 6	32
	Q - 8	32
	R - 6	34
	R - 8	34
	S - 3	36
	S - 9	36
	W - 10	48
	W - 21	48
014770622	B - 3	6
	B - 6	6
	C - 28	8
	D - 1-2	10

CODE	REF.NO.	PAGE
014770622	D - 13-2	10
	D - 16	10
	D - 17-5	10
	D - 35	10
	D - 51	12
	K - 1-2	20
	K - 12	20
	K - 14	20
	K - 16-2	20
	K - 6	20
	L - 22	22
	M - 37	24
	N - 2	28
	N - 37	28
	N - 50	28
	N - 62	30
	Q - 13-2	32
	Q - 16	32
	R - 9-2	34
	S - 11-1-1	36
	S - 11-2-1	36
	V - 7	46
	W - 8	48
	Z - 96	54
017066002	Z - 15	52
017680514	M - 29	24
017711412	W - 14	48
017762012	W - 3	48
017762202	E - 3	14
017771412	N - 70	30
018061222	G - 16	16
018061422	E - 22	14
018061622	A - 17	2
	V - 2	46
018062022	L - 31	22
018062222	G - 2	16
018081422	S - 5	36
018081622	L - 15	22
018082022	E - 9	14
	F - 2	16
	J - 2	18
018101622	S - 4-3	36
018680522	N - 76	30
018680822	N - 42	28
021060102	Z - 103	54
	Z - 92	54
021400106	Z - 111	54
021500106	Z - 41-4-3	54
	Z - 41-7-3	54
021660102	Z - 65-3	54
021680202	A - 103	4
	A - 69	2
	V - 15	46
021710202	E - 7-9	14
021860312	E - 7-13	14
021910302	M - 4	24
	N - 34	28
025030232	Z - 65-2	54
025060132	L - 21-3	22
025060232	A - 18	2
	G - 17	16
	P - 2	32
025060332	H - 6	18
	J - 1-6	18
	Z - 102	54
025080132	E - 28	14
	U - 1-5	44

CODE	REF.NO.	PAGE
025080232	J - 3	18
	L - 13	22
	L - 8	22
	S - 6	36
	W - 12	48
025100132	E - 25	14
	E - 7-16	14
	E - 7-19	14
	E - 7-3	14
	M - 34	24
	S - 4-4	36
	Z - 100	54
025350132	W - 35	48
025350332	P - 3	32
025680132	A - 84	4
	G - 19	16
	N - 60	28
	N - 66	30
	T - 33	40
	T - 53	42
	V - 16	46
	Y - 13-10	50
025680232	A - 77	4
	M - 44	24
	M - 58	26
	V - 23	46
	V - 26	46
	V - 55	46
	Y - 13-4	50
025710232	M - 28	24
025770232	A - 80	4
	E - 36	14
025900232	C - 33	8
	M - 3	24
028050240	E - 7-8	14
028050242	M - 41	24
028050246	Z - 41-7-2	54
028080242	L - 14	22
028680242	M - 59	26
	V - 56	46
031452206	Z - 41-2-2	54
032422003	Z - 84	54
047301842	K - 4	20
048030342	W - 18	48
048040342	L - 21-4	22
	T - 42	40
048050342	D - 20	10
	U - 1-15	44
048060342	A - 81	4
	E - 29	14
	G - 1-5	16
	L - 9	22
	U - 1-6	44
	W - 11	48
048070342	A - 97	4
048080342	M - 35	24
	W - 23	48
	Z - 99	54
048100142	E - 26	14
	E - 7-17	14
	E - 7-4	14
	J - 1-10	18
048110142	M - 17	24
048120142	V - 5	46
048150142	C - 15	8
	C - 31-4	8
	Q - 9	32

CODE	REF.NO.	PAGE
048170142	F - 1-11	16
048250142	C - 13	8
048350242	C - 31-3	8
050501406	Z - 41-7-5	54
050503006	Z - 41-7-4	54
062060806	Z - 41-2-1	54
062401406	Z - 112	54
062501406	Z - 41-4-2	54
062660416	Y - 12	50
062670412	Y - 13-6	50
062670512	S - 65	38
	T - 30	40
	W - 32	48
062670612	A - 36	2
	P - 4	32
	S - 21	36
	S - 73	38
	U - 1-13	44
062680512	D - 25	10
	T - 32	40
	Y - 13-3	50
062680612	A - 49	2
	A - 83	4
	K - 24	20
	N - 59	28
	N - 65	30
	R - 15	34
	S - 63	38
	T - 36	40
	T - 51	40
	V - 22	46
062680812	A - 21	2
	A - 63	2
	A - 66	2
	A - 68	2
	L - 26	22
	N - 75	30
	S - 28	36
	S - 31	36
	S - 38	36
	T - 46	40
	U - 1-4	44
062681012	A - 76	4
	M - 5-11	24
	M - 5-6	24
	M - 5-8	24
	S - 68	38
	V - 45	46
	Z - 17	52
062681212	A - 91	4
	L - 20	22
	M - 5-15	24
	M - 5-2	24
	M - 5-4	24
062681412	S - 46	36
	V - 20	46
062681612	D - 37	10
062710612	G - 12	16
062710812	A - 39	2
	A - 89	4
	N - 54	28
	U - 2	44
062711012	R - 14	34
062711212	S - 18	36
062711412	A - 24	2
	A - 28	2
	A - 31	2

CODE	REF.NO.	PAGE
062711412	A - 44	2
	M - 40	24
062760812	E - 32	14
	V - 47	46
062761212	E - 14	14
	J - 1-5	18
	N - 22	28
	N - 40	28
062761612	T - 40	40
062771012	H - 7	18
072600040	S - 4-2	36
072600360	F - 1-10	16
	F - 1-6	16
072600560	C - 12	8
072620160	J - 1-4	18
072620200	Q - 10	32
072620260	C - 31-2	8
072630260	C - 7	8
081003670	A - 34	2
081006670	N - 16	28
	V - 51	46
081007070	N - 6	28
081010670	E - 37	14
081011070	N - 15	28
	N - 53	28
081011670	L - 40	22
081048070	C - 5	8
082102790	Z - 29	52
082102890	Z - 29	52
082102990	Z - 29	52
082103090	Z - 29	52
100022005	D - 53	12
100075004	E - 7-14	14
100136001	U - 9	44
	Y - 14-4	50
100250001	B - 2	6
100279101	L - 33	22
100402004	T - 18-8	40
100887001	Z - 4	52
101118001	Z - 115	54
101125000	Z - 116	54
101486001	D - 11	10
101572101	Z - 3	52
101671002	Y - 13-9	50
102843004	C - 10	8
	F - 1-14	16
103950003	T - 19	40
104449001	A - 50	2
104450101	A - 51	2
	F - 3	16
	Q - 2	32
104908004	P - 7	32
105161003	Y - 13-7	50
105234003	A - 93	4
105288002	Y - 2	50
105812003	D - 27	10
105970001	Y - 8	50
106436001	S - 78	38
106568003	M - 46	24
106588003	K - 18-3	20
	V - 33	46
	W - 4	48
107017002	A - 42	2
	A - 47	2
107153001	S - 71	38
107153002	G - 1-4	16
107200001	N - 74	30

CODE	REF.NO.	PAGE
107205001	Z - 18	52
107207001	Z - 18	52
107210001	Z - 18	52
107231002	K - 22	20
107321003	A - 41	2
	A - 46	2
107401001	M - 48-1-3	26
	Z - 40-1-3	52
107404001	M - 48-1-4	26
	M - 48-2-4	26
	Z - 40-1-4	52
	Z - 40-2-4	52
107407003	G - 18	16
	N - 56	28
	Y - 15	50
107419002	A - 107	4
107550002	M - 13	24
107744001	W - 15	48
107780001	Z - 6	52
108494001	Y - 14-2	50
108495001	Y - 14-3	50
109203001	S - 26	36
109837001	Z - 18	52
110067001	Y - 9	50
110161004	W - 17	48
110215002	W - 34	48
110367001	B - 4	6
	S - 12	36
110494001	W - 22	48
110495003	K - 11	20
	M - 36	24
110558001	D - 31	10
110641002	S - 25	36
110820101	T - 1	40
111237001	B - 5-3	6
111468001	B - 5-6	6
111865001	C - 35	8
112348001	S - 69	38
112364001	S - 50	38
112404001	V - 30	46
112467002	S - 17-8	36
112700001	K - 18-2	20
112751002	T - 23	40
	T - 25	40
	T - 48	40
113316001	T - 22	40
	T - 24	40
113590001	A - 3	2
114255002	Q - 3	32
114294001	T - 18-2	40
115007001	D - 32	10
	V - 4	46
115120001	N - 79	30
115157001	Z - 5	52
115188001	U - 8	44
115503001	N - 45	28
	V - 36	46
115544001	E - 7-6	14
115545001	E - 7-5	14
115546001	E - 7-7	14
115550001	E - 7-20	14
115551001	E - 7-18	14
115558002	E - 13	14
115559002	E - 35	14
115585001	E - 19	14
115947001	Z - 91	54
116016001	Z - 110	54

CODE	REF.NO.	PAGE
116662003	Z - 36	52
	Z - 85	54
116735000	B - 5-7	6
116795001	E - 38	14
116920001	C - 14	8
	Q - 17	32
117006001	E - 39	14
117348001	C - 26	8
117437102	Z - 109	54
117466000	Z - 13	52
117671002	D - 34	10
	V - 6	46
117934001	A - 52	2
118764002	U - 14	44
118837001	Z - 2	52
120448001	U - 1-10	44
	Z - 117	54
122771002	Y - 4	50
	Y - 7	50
122991001	Z - 94	54
126863001	Z - 41-10	54
140004001	B - 5-4	6
140430001	B - 5-8	6
140553102	B - 11	6
141248001	A - 92	4
141276001	F - 1-13	16
141309001	D - 1-1	10
141334001	D - 40	10
	E - 34	14
	L - 34	22
141351001	D - 50	12
	W - 7	48
141367001	K - 1-1	20
141376000	K - 15	20
	Z - 20	52
141378000	K - 15	20
	Z - 20	52
141379000	Z - 20	52
141380000	Z - 20	52
141381000	Z - 20	52
141382000	K - 15	20
	Z - 20	52
141384000	K - 15	20
	Z - 20	52
141400001	M - 6	24
141408001	M - 7	24
141439001	M - 47	26
141492001	V - 34	46
141494001	V - 48	46
141514001	V - 35-4	46
	Z - 21-4	52
141519001	W - 16	48
141590001	T - 54	42
141620001	Y - 13-8	50
141642000	S - 17-2	36
141643000	S - 17-1	36
141650000	S - 52	38
141711100	Z - 28	52
142268001	S - 72	38
142359001	S - 14	36
	S - 66	38
142374000	M - 31	24
142443001	Z - 1	52
142628001	M - 16	24
142667001	E - 7-2	14
142711001	A - 108	4
142721001	Z - 10	52

CODE	REF.NO.	PAGE
142745002	Z - 19	52
142748002	S - 23	36
142750001	S - 75	38
142750002	S - 22	36
142766001	S - 8	36
143713001	S - 42	36
143748001	Y - 11	50
143749001	Y - 10	50
143767006	Y - 14	50
143787001	A - 71	2
143915001	S - 11-1	36
143971001	Z - 65	54
143980001	Y - 14-1	50
144103003	T - 12	40
	T - 3	40
144104001	T - 4	40
144105000	T - 14	40
	T - 5	40
144226001	Z - 39	52
144505000	U - 10	44
144526001	T - 44	40
144628001	Y - 6	50
144630001	M - 48-2-1	26
144707001	M - 48-2-3	26
	Z - 40-2-3	52
144741001	T - 18-1	40
144876001	S - 17-7	36
144997001	Y - 3	50
144998001	Y - 1	50
144999001	Y - 5	50
145136001	Z - 40-2-1	52
145247001	W - 39	48
145318001	W - 37	48
	W - 41	48
145446001	T - 10	40
	T - 18-5	40
	T - 2	40
	U - 7	44
145465001	B - 5-1	6
	S - 17-5	36
145480001	D - 22	10
	L - 29	22
145519001	T - 18-4	40
146000001	Y - 13-5	50
146198001	U - 13	44
146199001	U - 12	44
146200001	U - 11	44
146254001	Z - 38	52
146293001	D - 33	10
148469001	S - 17-3	36
148470001	S - 17-4	36
148471001	S - 17-6	36
148761001	S - 17	36
149095001	L - 39	22
149247001	Z - 34	52
149547000	S - 70	38
149566002	T - 15-1	40
	T - 6-1	40
149799000	S - 74	38
150106002	Z - 41-4	54
150172002	Z - 41-3	54
150173002	Z - 41-4-1	54
150174000	Z - 41-5	54
150179002	Z - 41-7-1	54
150180000	Z - 41-8	54
150182000	Z - 41-9	54
150189002	Z - 41-1	54

CODE	REF.NO.	PAGE
150335001	Z - 9	52
150553003	T - 55	42
150554002	N - 72	30
150756000	A - 35	2
	S - 10	36
151059001	A - 2	2
151605002	Z - 27	52
151932001	K - 21	20
152750001	M - 22	24
152765001	Z - 7	52
152948001	S - 24	36
152997001	E - 20	14
153057002	M - 43	24
	M - 57	26
	N - 44	28
	V - 25	46
153138001	D - 21	10
154528001	U - 1-9	44
154578000	A - 101	4
154702001	Z - 24	52
155696002	T - 15	40
155696003	T - 6	40
155697002	T - 15-2	40
155697003	T - 6-2	40
156641001	D - 4	10
158823001	N - 61-2	30
158824001	N - 61	28
158825006	A - 4	2
158827000	Z - 86	54
158828000	Z - 87	54
158830001	Z - 97	54
158831001	Z - 98	54
158832000	Z - 101	54
158833001	A - 19	2
158834000	A - 20	2
158836006	A - 22	2
158837000	A - 23	2
158838006	A - 26	2
158839000	A - 27	2
158840006	A - 29	2
158841000	A - 30	2
158842001	A - 32	2
158843001	A - 33	2
158844001	A - 37	2
158845006	A - 38	2
158847001	A - 40	2
158849006	A - 43	2
158851001	A - 45	2
158852002	A - 48	2
158864001	A - 64	2
158865001	A - 65	2
158866006	A - 62-1	2
158867001	A - 62-2	2
158868001	A - 62-3	2
158869001	A - 67	2
158870006	A - 70	2
158875001	A - 72	2
158876001	A - 74	2
158877001	A - 75	2
158879001	A - 78	4
158880000	B - 1	6
158882000	A - 53	2
158884201	B - 8	6
158885201	B - 8-1	6
158886001	B - 12	6
158888001	B - 13	6
158889001	B - 15	6

CODE	REF.NO.	PAGE
158891001	C - 1	8
158892001	C - 2	8
158893000	C - 3	8
	Q - 7	32
158894000	C - 4	8
158895001	C - 8	8
158896001	C - 9	8
158897001	C - 11	8
158898001	C - 16	8
158899006	A - 61	2
158901101	C - 24	8
158904001	C - 25	8
158906001	C - 31	8
158907001	C - 31-1	8
158908001	C - 31-5	8
158909001	C - 32	8
158910000	C - 34	8
158911001	D - 3	10
158913001	D - 5	10
158914001	D - 7	10
158915001	D - 9	10
158916000	D - 10	10
158917001	D - 13-1	10
158919101	D - 15	10
158920001	D - 17-3	10
158921001	D - 17-4	10
158922001	D - 17-6	10
158923001	D - 17-8	10
158924001	D - 17-9	10
158925001	D - 17-10	10
158926001	D - 19	10
158927001	D - 17-13	10
158928000	D - 17-12	10
158929001	D - 28	10
158930001	D - 23	10
158931001	D - 24	10
158932000	D - 18	10
158933001	D - 29	10
158935001	D - 38	10
158939001	D - 39	10
158940001	D - 41	10
158941001	C - 20	8
158942001	D - 43	10
158944001	D - 43-1	10
158945001	D - 44	10
158946001	D - 45	12
158947001	D - 17-1	10
158948001	D - 46	12
158950000	D - 47	12
158951000	D - 48	12
158952001	D - 49	12
158953001	E - 1	14
158955001	E - 1-1	14
158956001	E - 2	14
158957001	E - 4	14
158958101	E - 6	14
158959001	E - 8	14
158960001	E - 7-1	14
158961001	E - 10	14
158962001	E - 7-10	14
158963001	E - 7-11	14
158964001	E - 7-12	14
158965001	E - 7-15	14
158968001	E - 15	14
158969001	A - 95	4
158970001	E - 16	14
158971001	E - 18	14

CODE	REF.NO.	PAGE
158973001	E - 23	14
158974101	E - 24	14
158975001	E - 27	14
158976001	E - 31	14
158979001	E - 33	14
158980001	A - 90	4
158981101	F - 1-12	16
158984101	F - 1-3	16
158986101	F - 1-7	16
158987101	F - 1-8	16
158990001	G - 1-1	16
158991001	G - 1-2	16
158992001	G - 1-3	16
158993001	G - 3	16
158994001	G - 4	16
158995001	G - 8	16
158996001	G - 9	16
158997001	G - 11	16
158998001	G - 13	16
158999100	G - 14	16
159000101	G - 15	16
159001001	H - 1	18
159002001	H - 2	18
159003001	H - 3	18
159006001	H - 4	18
159007001	J - 1-1	18
159008001	J - 1-2	18
159011000	J - 1-3	18
159012001	J - 1-7	18
159013001	J - 1-9	18
159014101	L - 1	22
159015101	L - 1-1	22
159016001	L - 1-2	22
159017001	V - 21	46
159018001	L - 4	22
159020001	L - 5	22
159021001	L - 7	22
159022001	L - 10	22
159023001	L - 12	22
159024001	L - 16	22
159025001	L - 17	22
159026001	L - 19	22
159027001	L - 21-1	22
159028001	L - 21-2	22
159030000	L - 23	22
159031001	L - 25	22
159032000	L - 2	22
159033001	L - 27	22
159034000	L - 30	22
159035001	L - 32	22
159036001	M - 1	24
159037101	M - 5	24
159039101	M - 5-1	24
159040101	M - 5-3	24
159041101	M - 5-5	24
159042101	M - 5-7	24
159043001	M - 5-9	24
159044001	M - 5-10	24
159045001	M - 5-12	24
159046001	M - 5-14	24
159047001	M - 8	24
159048001	M - 9	24
159049001	M - 10	24
159050001	M - 11	24
159051101	M - 12	24
159054001	M - 14	24
159055001	M - 18	24

CODE	REF.NO.	PAGE
159056001	M - 19	24
159057001	M - 20	24
159058101	M - 21	24
159062001	M - 25	24
159063001	M - 27	24
159064000	M - 30	24
159065006	M - 32	24
159067001	M - 38	24
159069001	M - 42-1	24
159070001	M - 5-13	24
159071101	M - 45	24
159078001	M - 50	26
159079000	Z - 62-1	54
159080000	M - 49	26
	Z - 62-2	54
159082000	K - 3	20
159086001	K - 9	20
159087000	K - 10	20
159088001	K - 13	20
159090001	K - 16-1	20
159091001	K - 18	20
159092001	K - 19	20
159093000	K - 18-1	20
159094001	K - 20	20
159095101	K - 23	20
159096001	N - 1	28
159097001	N - 3	28
159098001	N - 4	28
159099001	N - 5	28
159100001	N - 8	28
159101000	N - 10	28
159102001	N - 11	28
159104001	N - 11-1	28
159105001	N - 12	28
159106001	N - 17	28
159107001	N - 18	28
159108001	N - 20	28
159109001	N - 21	28
159110001	N - 23	28
159111001	N - 24	28
	V - 10	46
	V - 40-3	46
159112001	N - 25	28
159113001	V - 12	46
	V - 40-5	46
159114001	N - 27	28
159115001	N - 28	28
159116001	N - 30	28
159117001	N - 31	28
159118000	W - 2	48
159119101	N - 33	28
159120001	N - 35	28
159121001	N - 39	28
159122001	N - 41	28
159123001	N - 43	28
159124001	N - 46	28
159126001	N - 47	28
159127001	N - 48	28
159128001	N - 49	28
159129001	N - 51	28
159130001	N - 52	28
159131101	N - 55	28
159132001	N - 57	28
159133001	N - 61-1	30
159135001	N - 63	30
159136001	N - 64	30
159137001	N - 67	30

CODE	REF.NO.	PAGE
159140001	N - 68	30
159141001	N - 69	30
159142101	N - 71	30
159143000	N - 73	30
159144001	P - 1	32
159145001	P - 5	32
159146101	P - 6	32
159147001	P - 8	32
159148001	P - 10	32
159150000	A - 25	2
	R - 3	34
159151001	R - 4	34
159153201	R - 7	34
159154001	R - 9-1	34
159155101	R - 11-1	34
159156201	R - 11-1-1	34
159157001	R - 11-1-3	34
	R - 11-2-3	34
159158001	R - 18	34
	Z - 12	52
159159001	R - 12	34
159160001	R - 13	34
159161001	R - 16	34
159162001	Q - 1	32
159163000	Q - 4	32
159164001	Q - 5	32
159166001	Q - 13-1	32
159169001	Q - 15	32
159170000	S - 1	36
159171000	S - 2	36
159172001	S - 4	36
159173001	S - 4-1	36
159174001	S - 7	36
159175000	S - 15	36
159178101	S - 19	36
159181001	S - 20	36
159182101	S - 27	36
159187000	S - 29	36
159188001	S - 30	36
159189000	S - 32	36
159190001	S - 33	36
159191000	S - 34	36
159192000	S - 35	36
159193000	S - 36	36
159194000	S - 39	36
159195000	S - 40	36
159199001	S - 41	36
159201000	S - 43	36
159203100	S - 45	36
159204001	S - 47	36
159205101	S - 48	36
159207101	S - 49	36
159209000	S - 51	38
159213001	S - 61	38
159214000	S - 62	38
159215001	S - 64	38
159218001	T - 7	40
159219101	T - 8	40
159220101	T - 9	40
159221001	T - 13	40
159222001	T - 18-3	40
159223001	T - 18-6	40
159224001	T - 20	40
159226001	T - 50	40
159228001	T - 28	40
159229001	T - 28-1	40
159234001	T - 29	40

CODE	REF.NO.	PAGE
159235101	T - 31	40
159236001	T - 34	40
159237001	T - 35	40
159238001	T - 37	40
159239001	T - 39	40
159240001	T - 41	40
159241001	T - 43	40
159242001	T - 45	40
159243001	T - 47	40
159252001	U - 1-8	44
159253001	U - 1-12	44
159256001	U - 4	44
159257001	U - 5	44
159259201	W - 1	48
159262000	V - 28	46
159263001	W - 6	48
159264001	W - 9	48
159265001	W - 13	48
159266101	W - 19	48
159267001	W - 20	48
159268001	W - 24	48
159269001	W - 25	48
159270001	W - 26	48
159271001	W - 27	48
159272001	W - 28	48
159274001	W - 30	48
	Z - 23	52
159275101	W - 31	48
159276201	W - 33	48
	Z - 22	52
159277101	W - 36	48
159281001	W - 40	48
159329001	N - 36	28
159331001	T - 18-7	40
159332000	Z - 83	54
159335001	V - 1	46
159336001	V - 3	46
159337101	V - 8	46
159341001	V - 9	46
159342101	V - 13	46
159343001	V - 14	46
159344001	V - 17	46
159345001	V - 18	46
159346101	V - 19	46
159348101	V - 24	46
159349001	V - 27	46
159354001	V - 29	46
159355001	V - 31	46
159356001	V - 32	46
159357001	V - 35	46
	Z - 21	52
159370001	V - 35-1	46
	Z - 21-1	52
159373001	V - 35-2	46
	Z - 21-2	52
159374001	V - 35-3	46
	Z - 21-3	52
159378001	V - 38	46
159379001	V - 39	46
159380001	V - 40-1	46
159381001	V - 40-2	46
159384001	Z - 35	52
159386001	Z - 26	52
159387001	Z - 26	52
159394001	L - 28	22
159395001	N - 29	28
159409101	B - 5	6

CODE	REF.NO.	PAGE
159420001	C - 22	8
159424001	C - 18	8
159425001	C - 21	8
159426001	D - 36	10
159427001	C - 17	8
159454000	Z - 95	54
159455000	A - 6	2
159458000	Z - 89	54
159491001	N - 13	28
159546101	T - 26	40
159547001	D - 17	10
159548001	E - 7	14
159550101	F - 1	16
159551001	J - 1	18
159552001	L - 21	22
159553001	G - 1	16
159554001	V - 46	46
159561001	B - 18	6
159562000	D - 42	10
159563000	M - 2	24
159564000	S - 53	38
159565000	S - 55	38
159566000	S - 56	38
159567000	S - 58	38
159568000	S - 59	38
159569000	S - 60	38
159570001	N - 38	28
159572000	B - 17	6
159594006	A - 62	2
159595000	A - 82	4
159601000	S - 37	36
159623001	T - 18	40
159624001	B - 12-1	6
159625001	D - 43-2	10
159633001	Z - 26	52
159634001	Z - 26	52
159715001	Z - 88	54
159744100	C - 29	8
159745100	Q - 11	32
159759001	W - 38-1	48
159761001	Z - 40-1-1	52
159762001	M - 48-1-1	26
159764001	Z - 40-1	52
159765001	M - 48-1	26
159768000	W - 5	48
159772101	Z - 93	54
159805001	T - 11	40
159818001	L - 18	22
159905001	D - 26	10
159906001	D - 52	12
159908001	N - 58	28
	T - 38	40
	S - 67	38
159909000	Z - 90	54
159910001	B - 8-2	6
159916001	T - 52	40
159917101	L - 35	22
159923001	L - 36	22
159924001	L - 37	22
159925001	M - 48-1-2	26
159926001	M - 48-2-2	26
	Z - 40-1-2	52
	Z - 40-2-2	52
159927001	M - 48-1-5	26
	M - 48-2-5	26
	Z - 40-1-5	52
	Z - 40-2-5	52

CODE	REF.NO.	PAGE
159928000	A - 73	2
	A - 96	4
159946001	V - 40-6	46
159947001	L - 38	22
159948001	V - 11	46
	V - 40-4	46
159989001	A - 98	4
180515001	S - 11-2	36
180721001	R - 11-1-3-2	34
	R - 11-2-3-2	34
183216101	B - 5-5	6
183490001	R - 11-1-2	34
	R - 11-2-2	34
183507001	R - 11-1-3-3	34
	R - 11-2-3-3	34
183508001	R - 11-1-1-1	34
183526001	R - 11-2-1-1	34
183596001	R - 11-1-1-2	34
	R - 11-2-1-2	34
183598001	R - 11-1-1-3	34
	R - 11-2-1-3	34
183702001	D - 1	10
183704001	K - 1	20
183707001	D - 13	10
183708001	K - 16	20
183709001	R - 9	34
183710001	Q - 13	32
602344001	F - 1-16	16

ブラザー工業株式会社

〒467 名古屋市瑞穂区河岸一丁目1番1号
TEL (052) 824-2392代

BROTHER INDUSTRIES LTD. NAGOYA, JAPAN Printed in Japan / Made in Japan / Imprimé au Japon / Impreso en Japón

118-815
195815-401 ①
1990, 05

From the Library of: Superior Sewing Machine & Supply LLC